

SECTION D-D

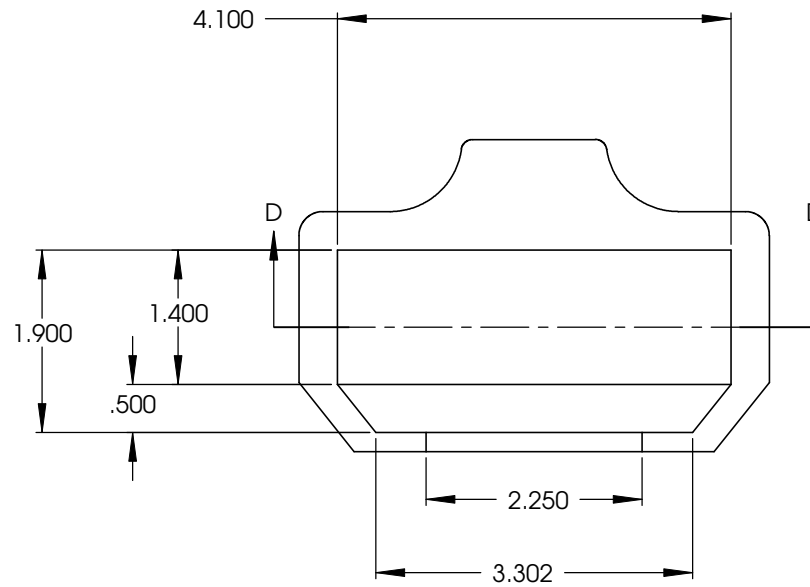

This drawing is the property of TIGER TOOL INTERNATIONAL INC. It is provided for confidential information purposes only and is not to be disclosed to anyone else or used for manufacturing purposes without the express written permission of TIGER TOOL INTERNATIONAL INC.

REV.	DATE	CHANGE MADE	BLANK: 0.0" DIA. X 0.0" LG.	UNLESS OTHERWISE SPECIFIED ALL DRAWING UNITS ARE IN INCHES	PART NAME:			
			MATERIAL:	TOLERANCES:	10385 PITMAN PULLER			
			HEAT TREAT:	DECIMALS: .X +/- .030"	FRACTIONS: +/- 1/16"	SIZE:	DWG. #:	REV.:
			FINISH:	.XX +/- .010"	ANGLES: +/- 0.5 DEG	A		
				XXX +/- .005"	SURF. FINISH: 125 RMS			
				DRAWN BY: R.V.	DATE: 00/00/00	SCALE: 1:2	DO NOT SCALE DRAWING	SHEET 1 OF 1