

AMGO  [®] **Hydraulics**

Original

Installation And Service Manual



CONTENTS

Product Features and Specifications	1
Installation Requirement.....	2
Steps of Installation.....	3
Exploded View.....	10
Operation Instruction.....	15
Maintenance	17
Trouble Shooting	18
Lift Disposal	18

I. PRODUCT FEATURES AND SPECIFICATIONS

PORTABLE MID-RISED MODEL MR06

- Manual safety lock: mechanical safety locks release, No need air source.
- High speed: From 0-1090mm (43") in just 21 seconds
- Portable design: It is easy to move the whole lift with the power unit stand
- Adjustable rubber pad included



Fig.1

MODEL MR06 SPECIFICATIONS

Model	Lifting Capacity	Raised Height	Lifting Time	Overall Length	Overall Width	Lowered Height	Motor
MR06	6,000 lbs	43"	26S	74 1/4"	66 1/4"	5"	2.0HP

II. INSTALLATION REQUIREMENT

A. TOOLS REQUIRED

↳ Screw Set



↳ English Spanner (12")



↳ Wrench sets: (13#, 15#, 17#, 19#)



↳ Grease gun



↳ Hook spanner (40~42mm)



↳ Pliers



Fig. 2

B. POWER SUPPLY

The electrical source must be 2.2kw minimum. The source cable size must be 2.5mm² and in good condition of contacting with floor.

III. INSTALLATION STEPS

A. Check the parts before assembly, make sure all the parts are completed.

1. Packaged lift, Parts box, Power Unit and Power Unit Stand.

Move the parts aside, open the outer packing and check the parts according to the shipment parts list (See Fig. 3).

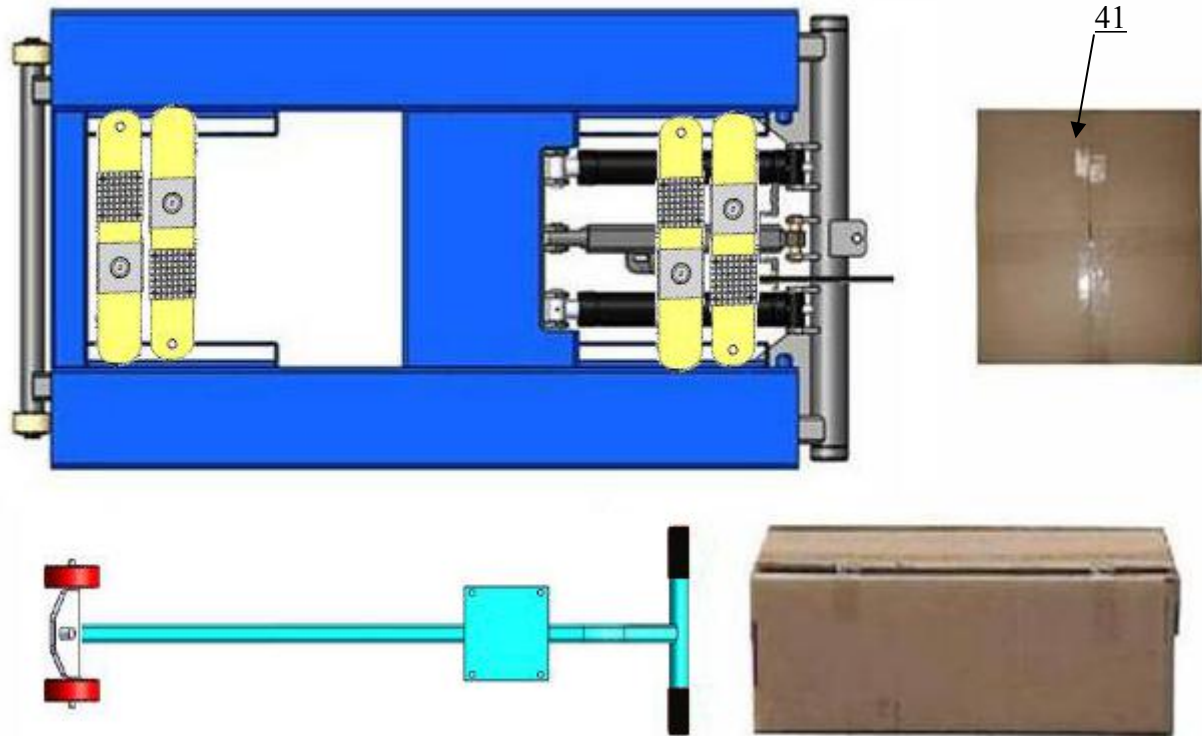

Fig. 3

2. Open the parts box, check the parts according to the part list (See Fig. 4).

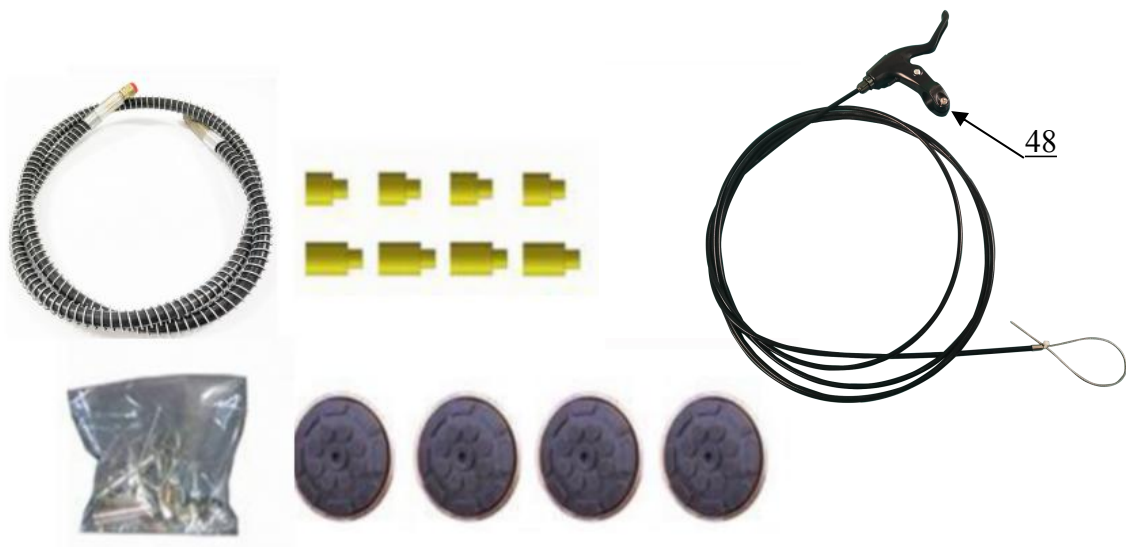

Fig. 4

3. Check the parts of the parts bag according to the parts bag list (**See Fig. 5**).



Fig.5

B. Install the brake

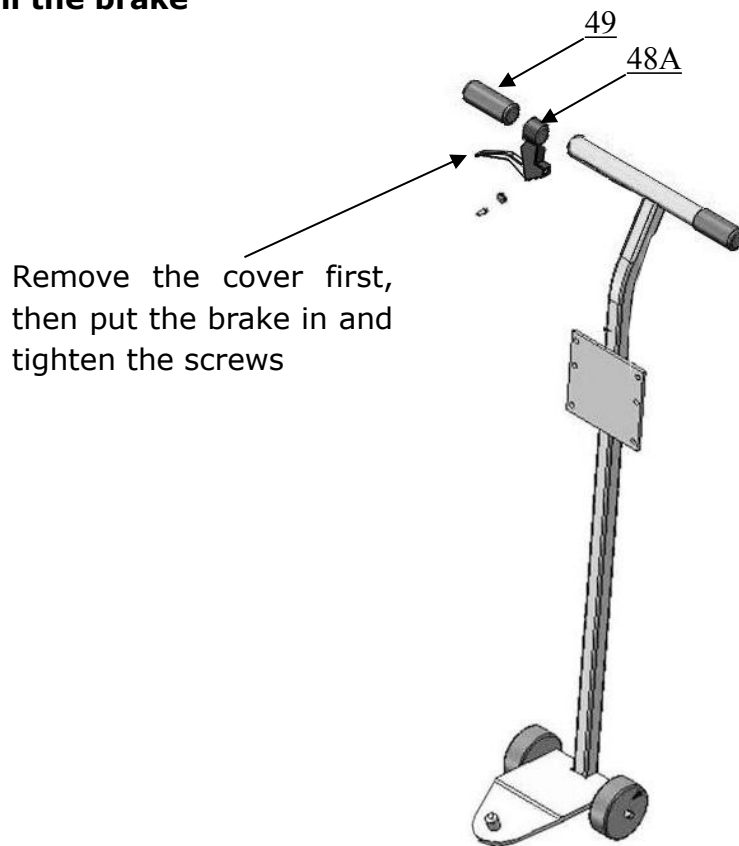

Fig.6

Then Install power unit and fitting (See Fig. 7)

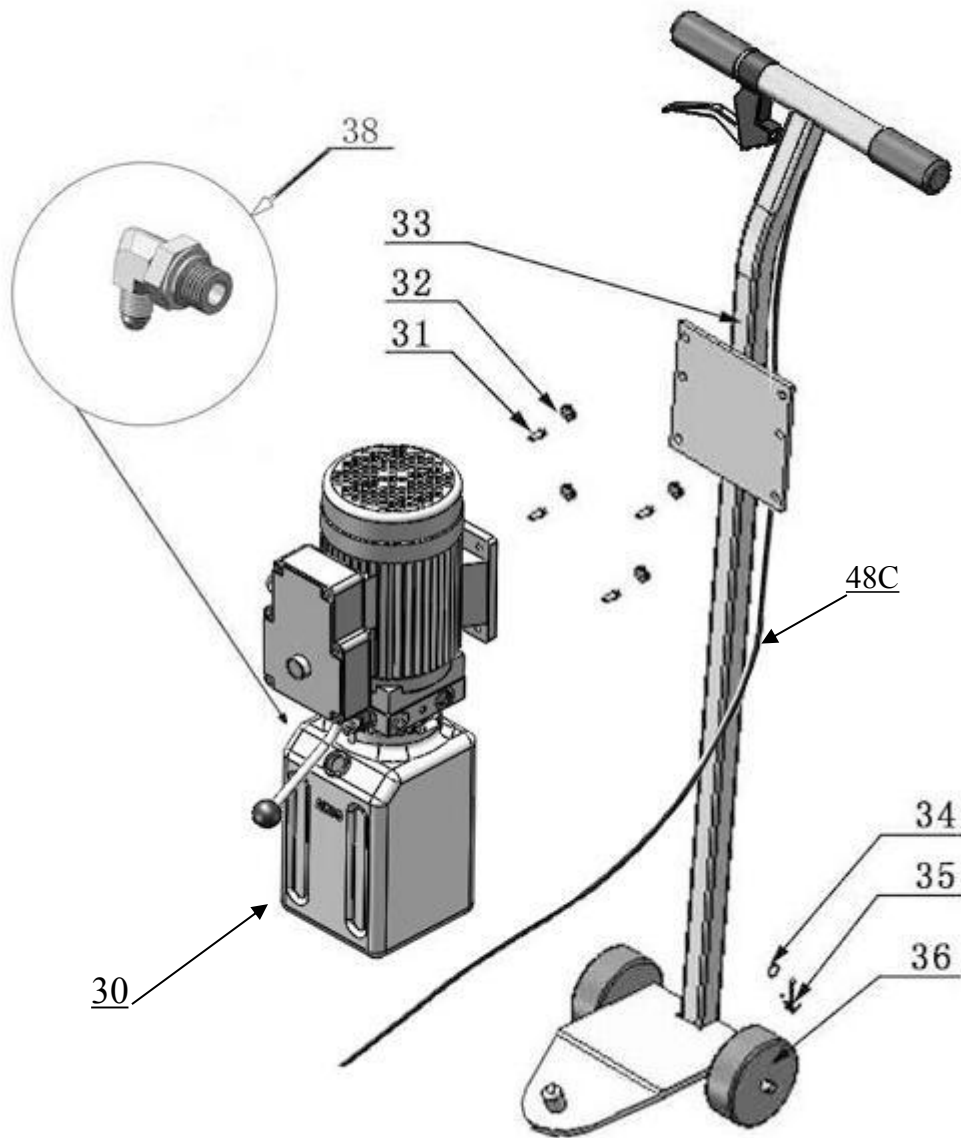

Fig. 7

C. Install oil hose (See Fig. 8)

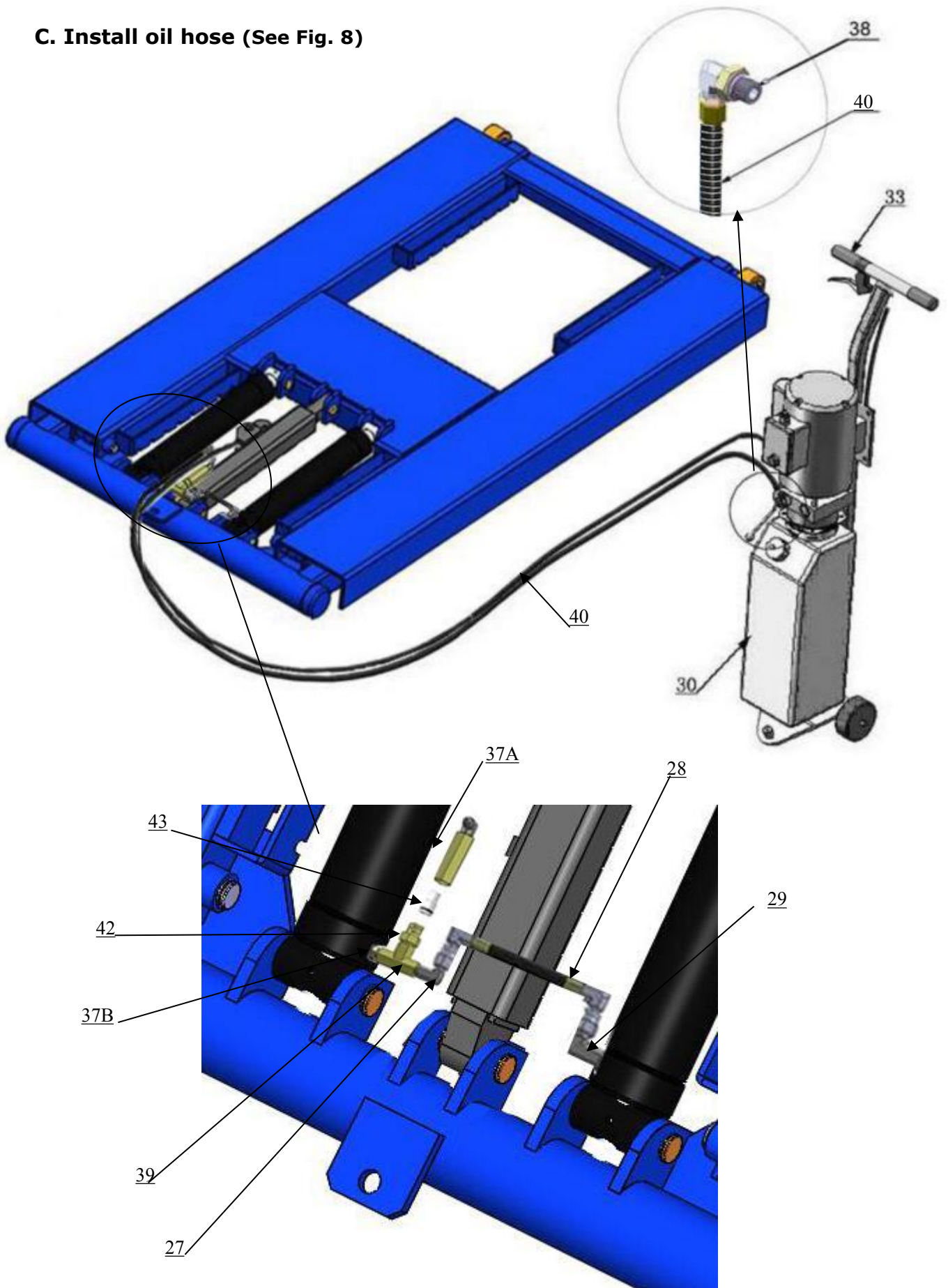

Fig. 8

D. Install safety device and cable

1. Put the safety device parts as Fig.9

The safety stop needs to be 10mm high, and then install wire cable

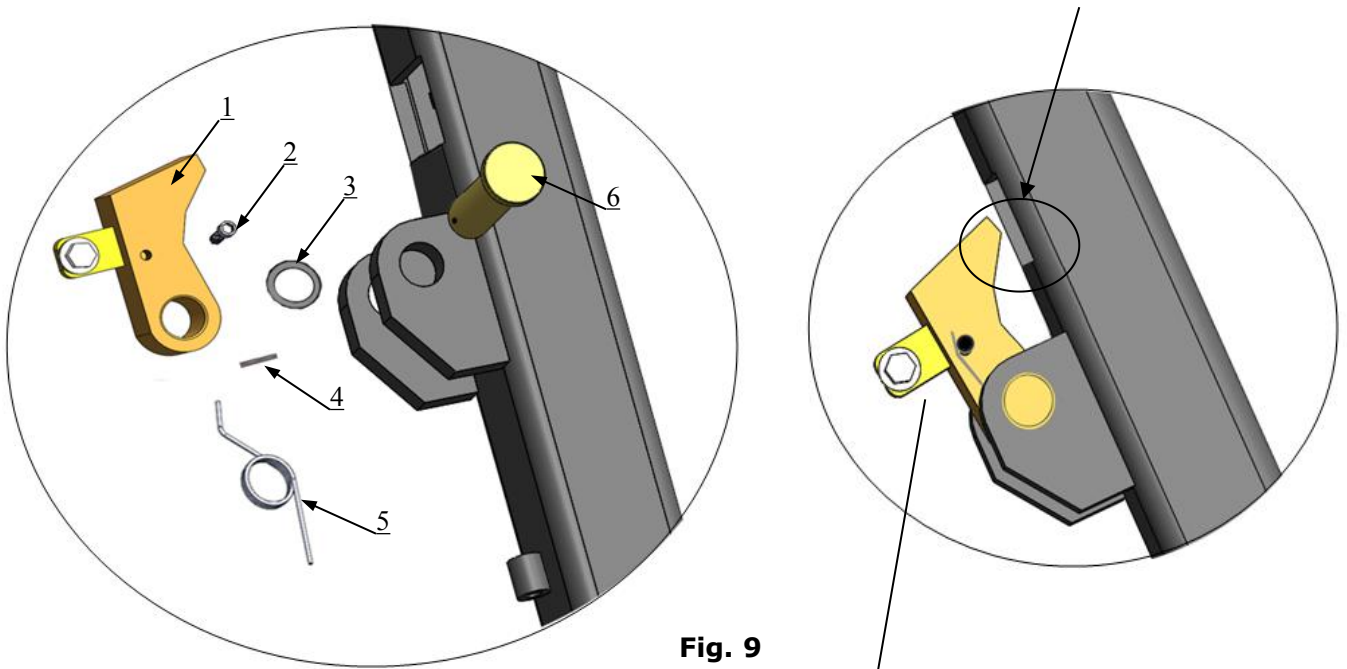

Fig. 9

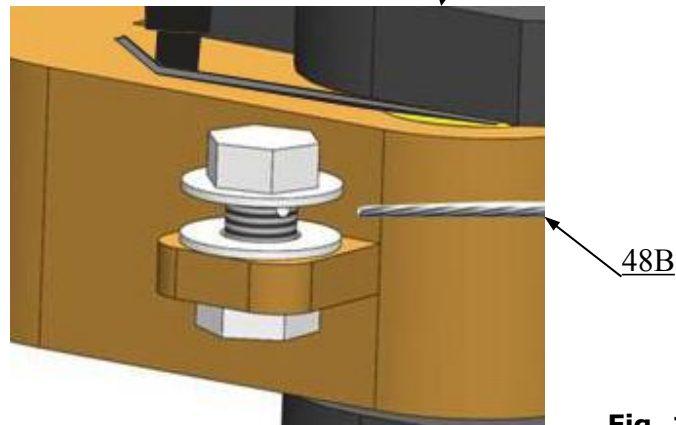

Fig. 10

Put the small wire rope into the hole on the screw and then tighten

Item	Part#	Description	QTY	Item	Part#	Description	QTY
1	11640150	Safety stop	1	4	1061K104	Split pinφ3*30	1
2	81400438	Hex bolt M5*10	1	5	10640155	Springφ23*φ27*2	1
3	10510053	Washer φ24*φ19.5*1.8	1	6	11640154	Safety pin	1

E. Install supporting arm

1. Raise the lift up to 39 3/8" and lock the safety device, then tighten the self-lock nut. (See Fig. 11) Note: Make sure the supporting arms can move left/right

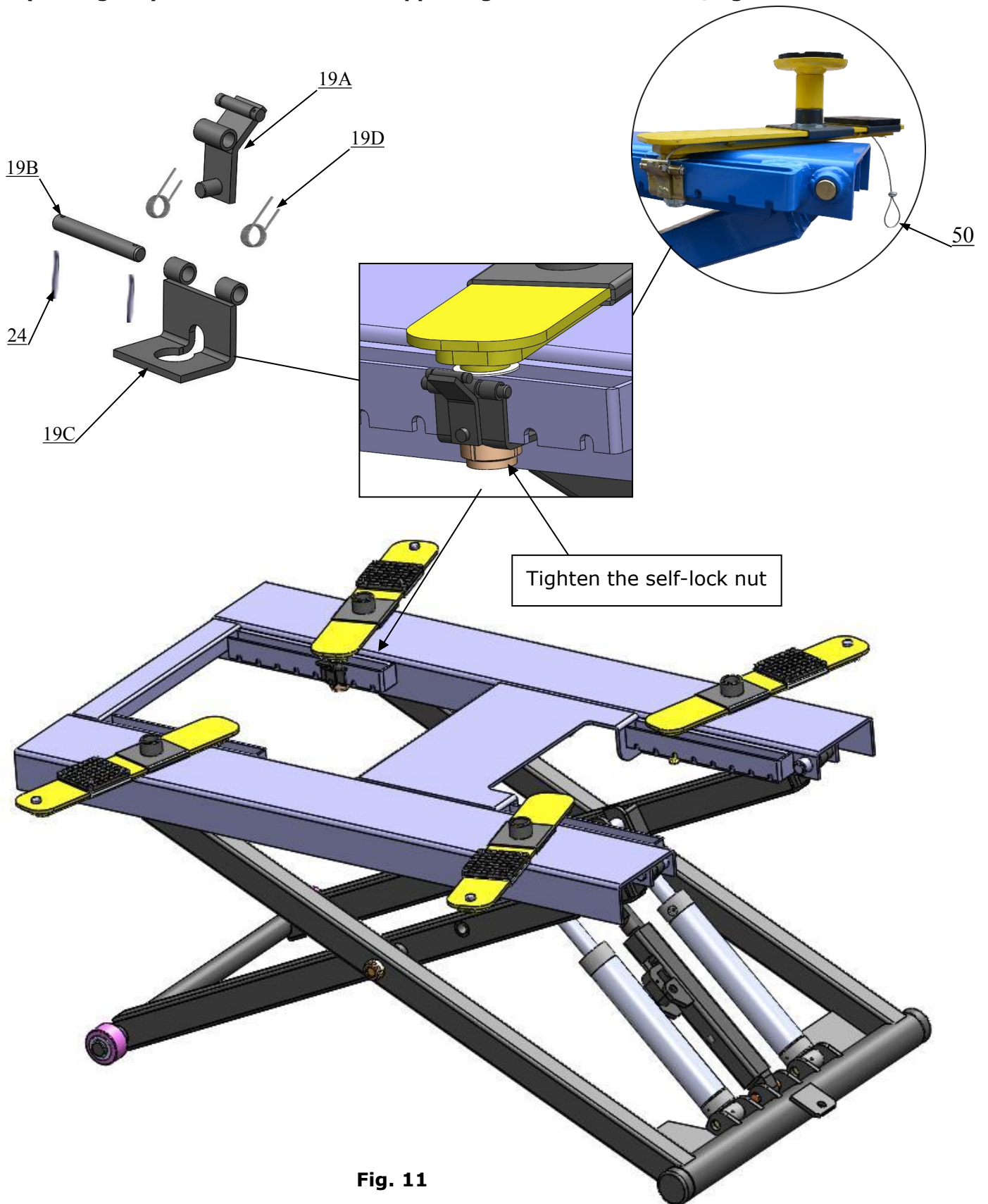

Fig. 11

F. Install electric system

Connect the power source on the data plate of Motor

Note:

1. For the safety of operators, the power wiring must be contacted the floor well.
2. Pay attention to the direction of rotations when using three phase motors.

Single phase motor (See Fig. 12)

1. Connecting the two power supply lines (fire wire **L** and zero wire **N**) to terminals of AC contactor marked **L1, L2** respectively.
2. Connecting the two motor wires to terminals of AC contactor marked **T1, T2**.
3. Connecting **L2** to **A2** of AC contactor.
4. Two wires of control button connected with terminals of AC contactor marked **A1, L1**.

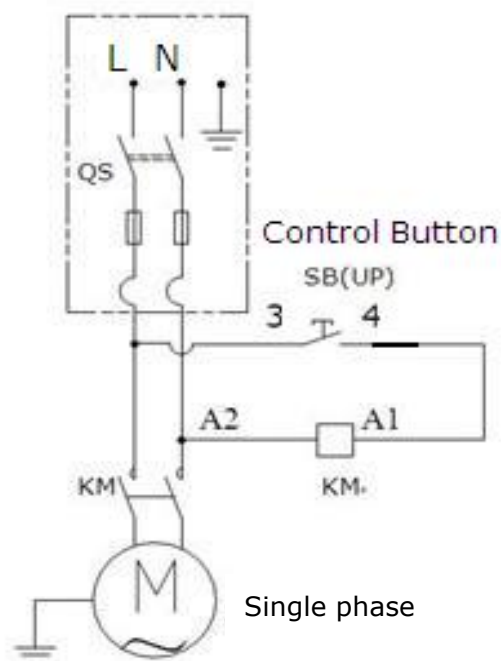
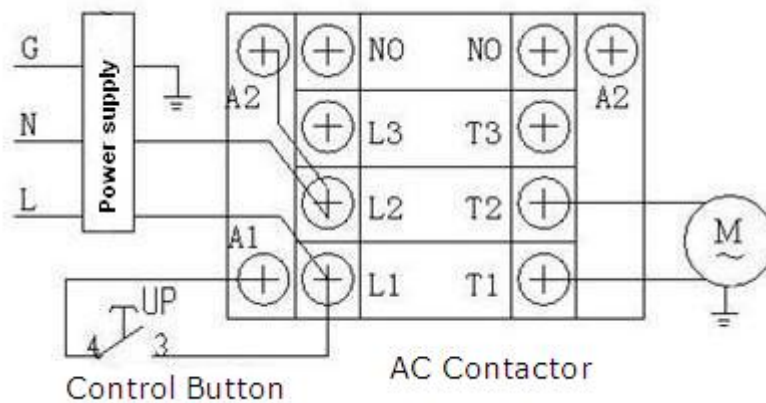

Fig. 12

IV. EXPLODED VIEW

Model MR06

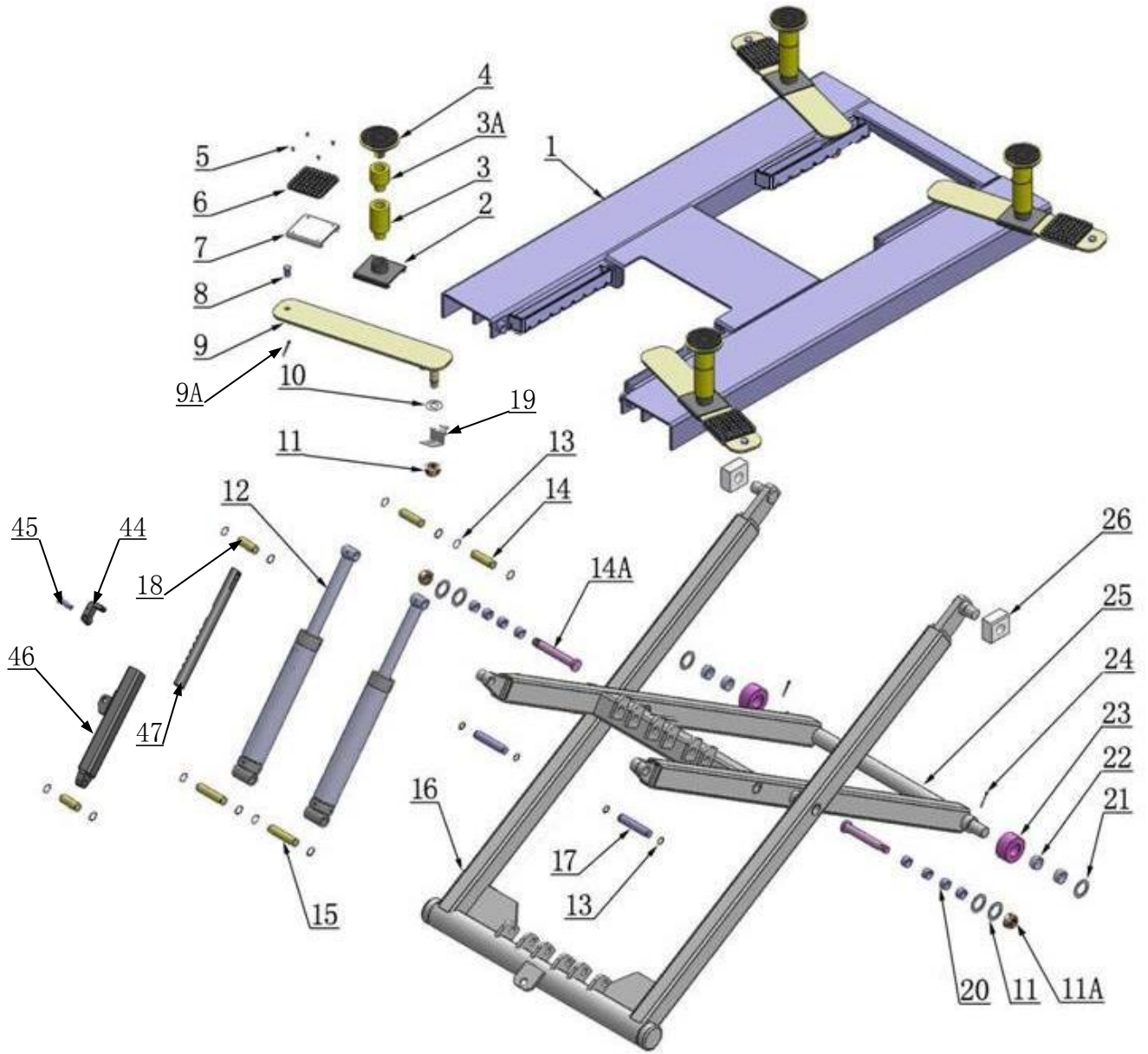

Fig. 13

PARTS LIST FOR MODEL MR06

Item	Part#	Description	QTY.	Note	
1	11640001	Platform	1		
2	11640002A	Stackable Adapter Bracket	4		
3	11209052B	Stackable Adapter (2.5")	4		
3A	11209051B	Stackable Adapter (1.5")	4		
4	10201046A	Rubber Pad Assy.	4		
4A	10420138	Socket bolt M6*16	4		
4B	10209134	Rubber pad	4		
4C	11680030C	Rubber Pad Frame	4		
5	10209009	Cap Head Bolt M6*8	16		
6	10680004	Rubber Pad	4		
7	10640003	Supporting pad	4		
8	11640023A	Limit pin	4		
9	11640004	Supporting arm	4		
10	10640005	Washer $\Phi 27$	10		
11	10640109	Washer $\Phi 44*\Phi 25.5*2$	4		
11A	10620022	Self-locking Nut M24*2.5	6		
12	10640116	Cylinder $\phi 70*290$	2		
13	10206032	Snap Ring $\Phi 25$	12		
14	11640057	Pin for Cylinder Connecting	2		
14A	11640012	Pin	2		
15	11640006A	Pin for Cylinder	2		
16	11640017B	Outer Scissor	1		
17	11640009	Inner Scissor Pin	2		
18	11640130	Safety Bar Set	2		
19	19A	11640134	Slide limit block	4	
	19B	11640135	Slide stop	4	
	19C	11640136	Safety Pin	4	
	19D	10640127	Spring	8	
20	10203004A	Bronze Bush $\Phi 31*\Phi 25.3*21$	8		
21	10420023A	Washer $\phi 36*\phi 65*3$	2		
22	10420132A	Bronze Bush $\Phi 41.2*\Phi 35.2*20$	4		
23	11640022	Roller	2		
24	10630107	Split Pin	10		
25	11640016B	Inner Scissor	1		
26	10610003A	Slider	2		
27	1061K107	Straight Fitting	1		
28	10640114	Oil Hose 1/4"*165(double 90°)	1		
29	10420097	Straight Fitting	2		
30	81513006/81513007	Manual Power Unit	1		
31	10209003	Hex Bolt	4		

Item	Part#	Description	QTY.	Note
32	10209005	Self-locking Nut	4	
33	10640138	Power Unit Stand	1	
34	10206006	Washer $\Phi 12$	2	
35	10201005	Split Pin	2	
36	10640023	Roller	2	
37A	10201020	90° Fitting 1/4JIC(M)*3/8NPT(M)	1	
37B	10209119	compensation valve	1	
38	10209060	Straight Fitting for Power Unit	1	
39	10206062	T Fitting 1/4NPT (M) *1/4NPT (M)	1	
40	1003015002	Oil Hose Assy (with spring)	1	
41	10640500A	Parts Box	1	
42	10420244	Straight fitting 1/4NPT(M)*G3/8(M)	1	
43	10420245	Straight fitting 3/8NPT(F)*G3/8(F)	1	
44	11640150	Safety block	1	
45	11640131	Safety block pin	1	
46	11640153	Self-lock supporting tube	1	
47	11640152	Self-lock supporting pin	1	
48	10640141	Safety lock control assy.	1	
48A	10640115	Safety lock control handle	1	
48B	10640156	Safety cable $\phi 1.5 \times 4345\text{mm}$	1	
48C	10640121	Safety cable tube $\phi 5 \times \phi 2 \times 4060\text{mm}$	1	
49	10640126	Rubber tube	1	
50	10640133	Arm lock cable $\phi 2.5 \times 810\text{mm}$	4	

4.1. CYLINDER (10640116)

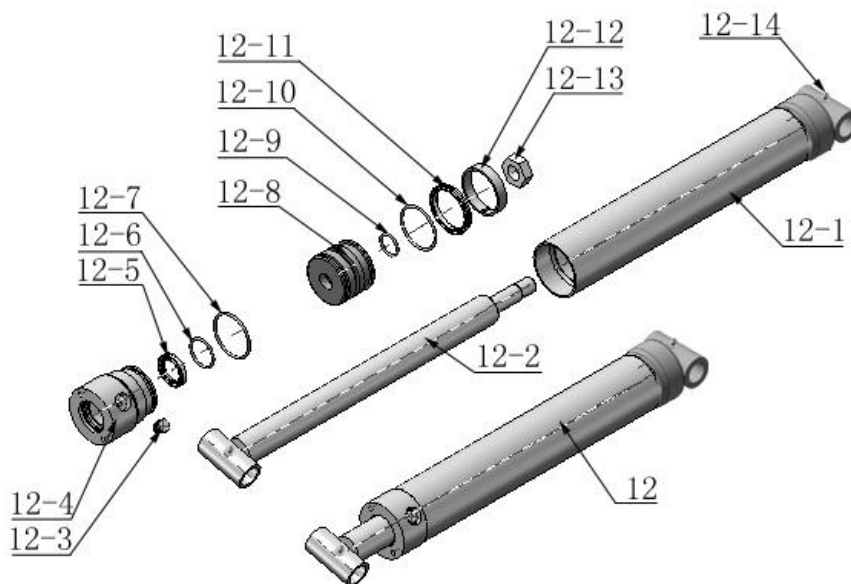

Fig.14

PARTS FOR HYDRAULIC CYLINDER				
Item	Part#	Description	QTY.	Note
12-1	11640657	Bore Weldment	2	
12-2	11640031A	Piston Rod	2	
12-3	10201034	Bleeding Plug	2	
12-4	11203083	Head Cap	2	
12-5	10209078	Dust Ring	2	
12-6	10201032	O-Ring inside head cap	2	
12-7	10203084	O-Ring outside head cap	2	
12-8	11203079	Piston	2	
12-9	10206069	Small O-Ring for piston	2	
12-10	10203082	O-Ring outside piston	2	
12-11	10410087	Y-Ring OSI	2	
12-12	10410086	Support Ring	2	
12-13	10206071	Nut	2	
12-14	10620064	Greasing Fitting	4	

2 MANUAL POWER UNIT (071104)

220V/60HZ/1 phase

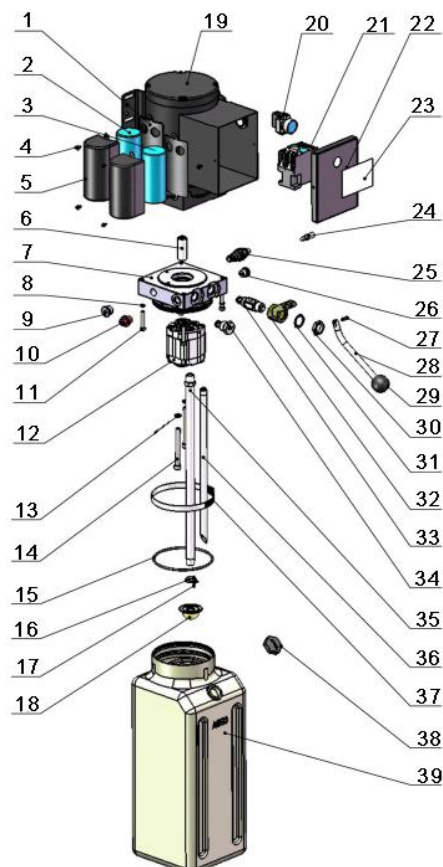

Fig.15

Parts for Manual power unit

Item	Part#	Description	QTY.	Note
1	81400180	Rubber pad	2	
2	81400130	Start capacitor	1	
3	81400088	Run capacitor	1	
4	10420148	Cap head bolt with washer	4	
5	81400066	Cover for capacitor	2	
6	81400363	Motor connecting shaft	1	
7	090106	Manifold block	1	
8	10209149	Lock washer	4	
9	81400276	Iron plug	1	
10	81400259	Red rubber plug	1	
11	85090142	Socket bolt	4	
12	81400280	Gear pump	1	
13	10209034	Washer	2	
14	81400295	Socket bolt	2	
15	81400365	O-ring	1	
16	10209152	Belt	1	
17	85090167	Magnet	1	
18	81400290	Filter mesh	1	
19	81400413	Motor	1	
20	10420070	Button switch	1	
21	41030055	AC contactor	1	
22	81400287	Cover of motor terminal box	1	
23	71111174	AMGO label	1	
24	81400560	Throttle valve	1	
25	81400266	Release valve	1	
26	81400284	Iron plug	1	
27	10720118	Elastic pin	1	
28	81400451	Handle for release valve	1	
29	10209020	Plastic ball for arm lock	1	
30	81400421	Release valve nut	1	
31	81400422	Release valve shim	1	
32	81400449	Valve seat(Low)	1	
33	070001	Release valve	1	
34	070002	Check valve	1	
35	81400288	Oil suction pipe	1	
36	814002889	Oil return pipe	1	
37	81400364	Hose clamp (stainless steel)	1	
38	81400263	Oil tank cap	1	
39	81400320	Oil tank	1	

Manual Power unit single phase (See.Fig16)

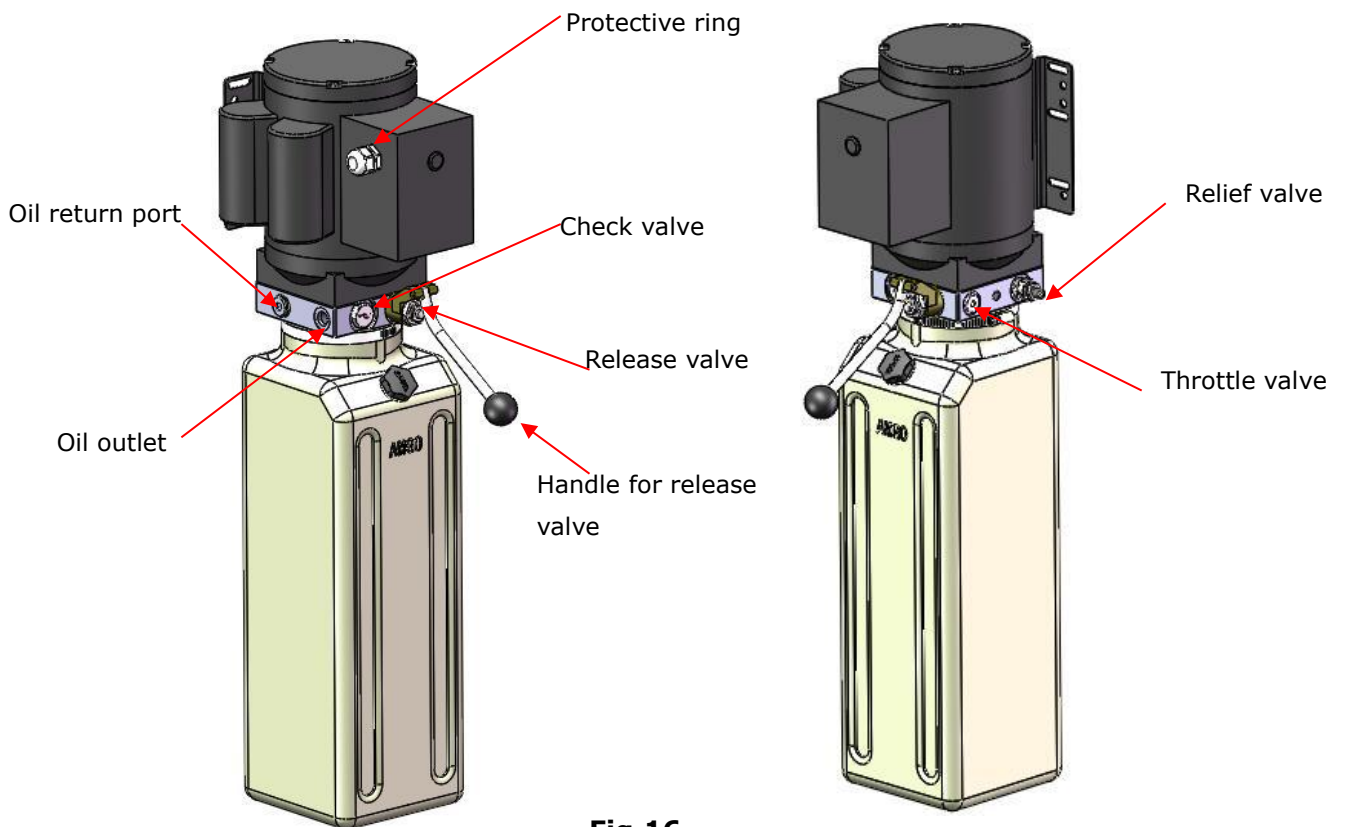
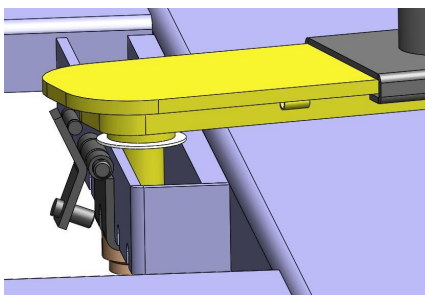

Fig.16

V. OPERATION INSTRUCTIONS

1. Install the oil hose between oil cylinder and power unit, connect with the power supply wire well. The machine can be ready to use.
2. When lifting vehicle, be sure the center of gravity of vehicle must be in the middle of lift, select the suitable adapters , pull the small cables of the yellow supporting arms to open the lock, and move the arms to find the support point. (See **Fig.18,19**)Make sure the safety lock must be in engaged when lifting (See **Fig. 20**).
3. Lower the lift: Press the button "UP", until the safety lock is in released position clench the brake handle (See **Fig.21,22**), lower the lift by pushing lowering handle.



Pull cable to move supporting arm

Fig. 17

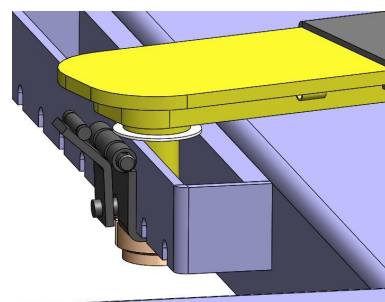

loose cable to fasten supporting arm

Fig.18

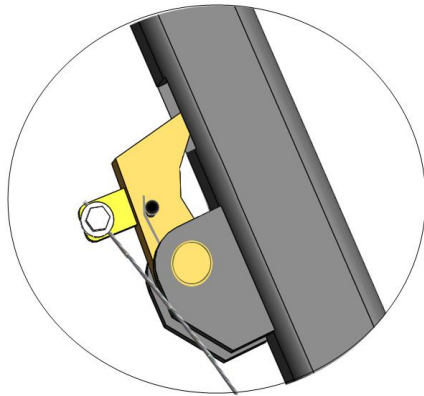

Safety engaged

Fig.19

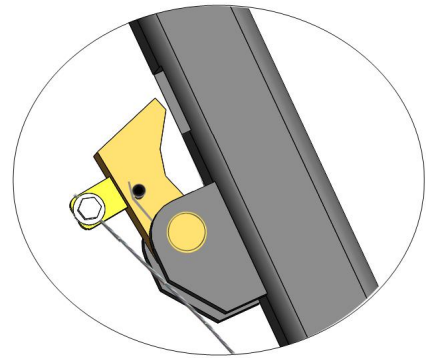

Safety released

Fig.20

Clench the brake handle to release

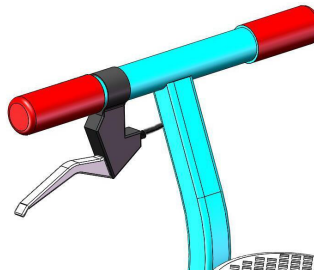

Fig.21

4. Move the lift with the power unit stand (See Fig. 22)

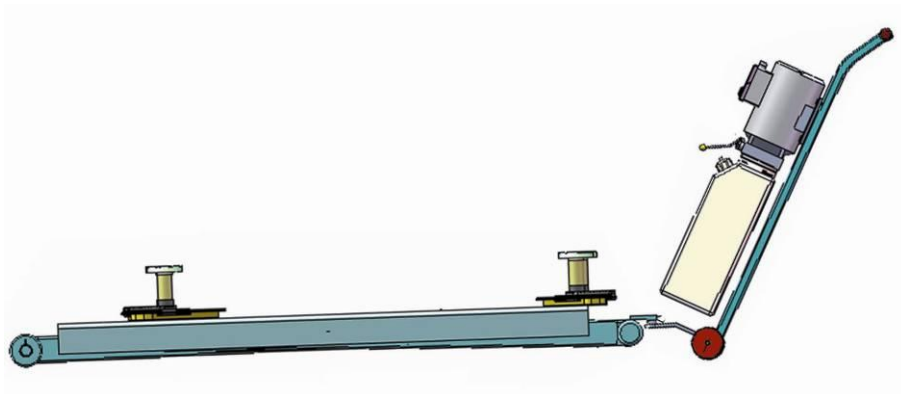
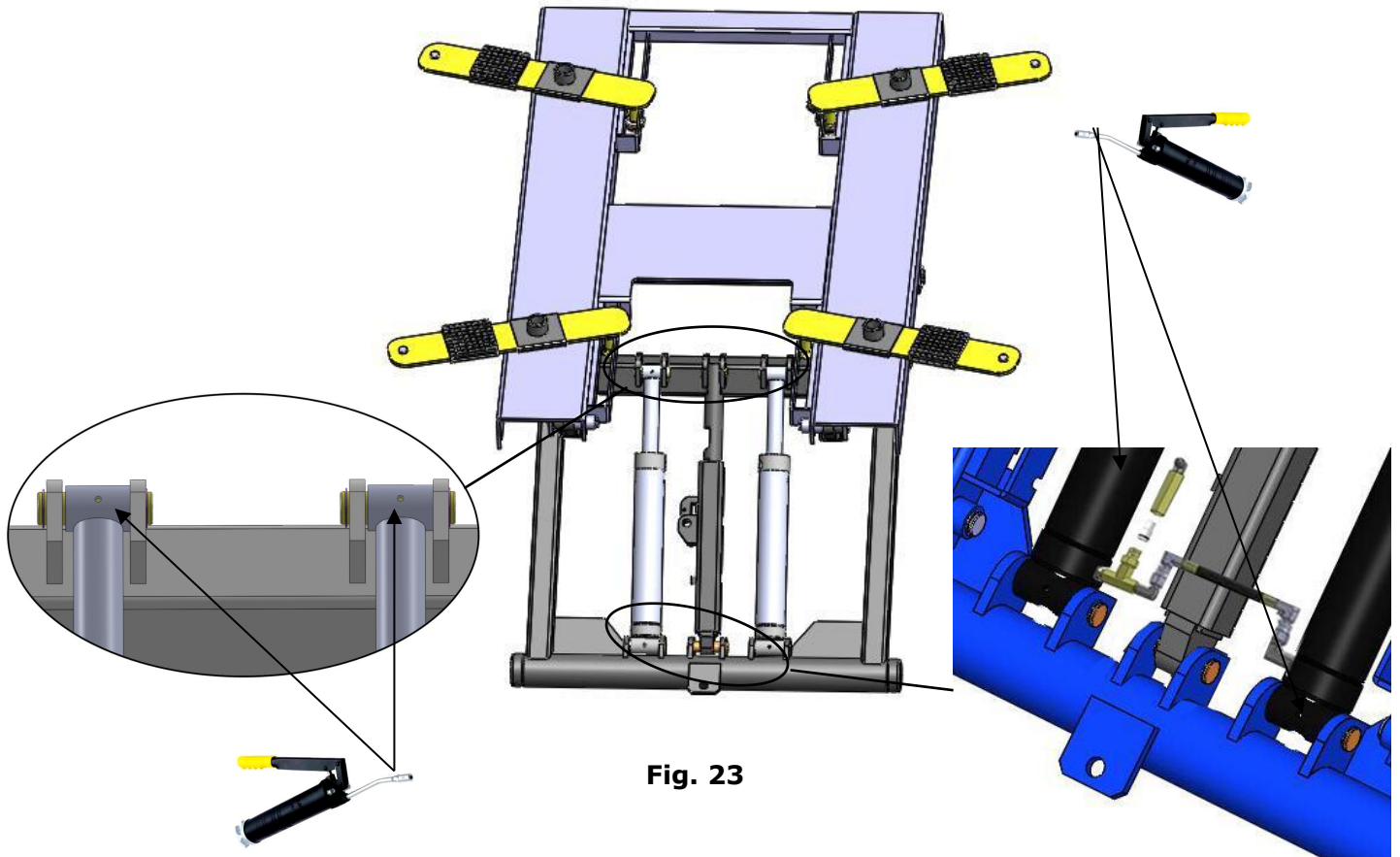

Fig. 22

VI. MAINTENANCE SCHEDULE

Monthly:

1. Lubricate all moving parts with lubricant (See Fig.23).



2. Check all connectors, bolts and pins to insure proper mounting.
3. Make a visual inspection of all hydraulic hoses/lines for possible wear or leakage.

Every six months:

1. Make a visual inspection of all moving parts for possible wear, interference or damage.
2. Check all fastener and re-torque.

Oil cylinder maintenance:

In order to extend the service life of the oil cylinder, please operate according to the following requirements.

1. Recommend to use N46 anti-wear hydraulic oil.
2. The hydraulic oil of the lifts should be replaced regularly during using. Replace the hydraulic oil 3 months after the first installation, Replace the hydraulic oil once a year afterwards.

3. Make at least one full trip raising and lowering per day. For exhausting the air from the system, which could effectively avoid the corrosion of the cylinder and damage to the seals caused by presence of air or water in the system.
4. Protect the outer surface of the oil cylinder's piston rod from bumping and scratching, and timely clean up the debris on the oil cylinder dust-ring and the piston rod.

VII. TROUBLE SHOOTING

TROUBLE	CAUSE	REMEDY
Motor does not run	<ol style="list-style-type: none"> 1. Button does not work 2. Wiring connections are not in good condition 3. Motor burned out 4. Safety Switch is damaged 5. AC contactor burned out 	<ol style="list-style-type: none"> 1. Replace button 2. Repair all wiring connections 3. Repair or replace motor 4. Replace the Safety Switch 5. Replace AC Contactor
Motor runs but the lift is not raised	<ol style="list-style-type: none"> 1. Motor runs in reverse rotation 2. Gear Pump out of operation 3. Release Valve in damage 4. Relief Valve or Check Valve in damage 5. Low oil level 6. Overload lifting or low pressure 	<ol style="list-style-type: none"> 1. Reverse two power wire 2. Repair or replace 3. Repair or replace 4. Repair or replace 5. Fill tank 6. Check load or adjust the pressure
Lift does not stay up	<ol style="list-style-type: none"> 1. Release Valve out of work 2. Relief Valve or Check Valve leakage 3. Cylinder or Fittings leaks 	Repair or replace
Lift raises slowly	<ol style="list-style-type: none"> 1. Oil line is jammed 2. Motor running on low voltage 3. Oil mixed with air 4. Gear Pump leaks 5. Overload lifting 	<ol style="list-style-type: none"> 1. Clean the oil line 2. Check Electrical System 3. Fill tank 4. Repair or replace 5. Check load
Lift cannot lower	<ol style="list-style-type: none"> 1. Safety device are in activated 2. Release Valve in damage 3. Oil system is jammed 	<ol style="list-style-type: none"> 1. Release the safeties 2. Repair or replace 3. Clean the oil system

VIII. Lift disposal.

When the car lift cannot meet the requirements for normal use and needs to be disposed, it should follow local laws and regulations.



AMGO HYDRAULIC CORPORATION

1931 Joe Rogers Blvd, Manning, South Carolina,

Zip:29102

Tel: (803) 505-6410

fax: (803) 505-6410

Manual Part No.: 72215601

Revision Date: 2020/07