

Pneumatic Motorcycle Lift

PRO 1000

Capacity 1,000lbs

Installation, Operation & Maintenance Manual



(SHOWN WITH OPTIONAL MOTORCYCLE VISE)

WARNING: READ INSTRUCTIONS BEFORE OPERATING

Jun 2018



READ ENTIRE MANUAL TO COMPLY WITH ALL SAFETY AND SERVICE PRECAUTIONS. DEATH, PERSONAL INJURY AND/OR PROPERTY DAMAGE MAY OCCUR UNLESS INSTRUCTIONS ARE FOLLOWED CAREFULLY.

UNPACKING AND SET-UP

- Open crate, then remove ramp and shipping boards.
- Carefully remove lift from crate. (*Note: Lift is specifically shipped upside-down.*)
- Carefully, flip lift over to normal upright orientation.
- Install tie-down eyelets to front corners of platform.
- Locate & connect foot-operated air valve to 100 psi air supply.



The lift may be damaged and/or personal injury may result if the pressure exceeds the maximum 100 psi rating.

- Stand clear of lift platform, and depress the UP side of foot valve to raise platform.
- To lower platform, lift safety latch bar from safety latches and lower to next position or to floor. (*Note: The latch bar can also be held in position to fully lower lift by clipping to underside of platform.*)
- Install approach ramp by inserting into holes at rear end of platform.
- Install stabilization bar by removing the cap at one end, then insert bar through square hole in base of scissor mechanism. Secure with nut & bolt hardware and reinstall cap.

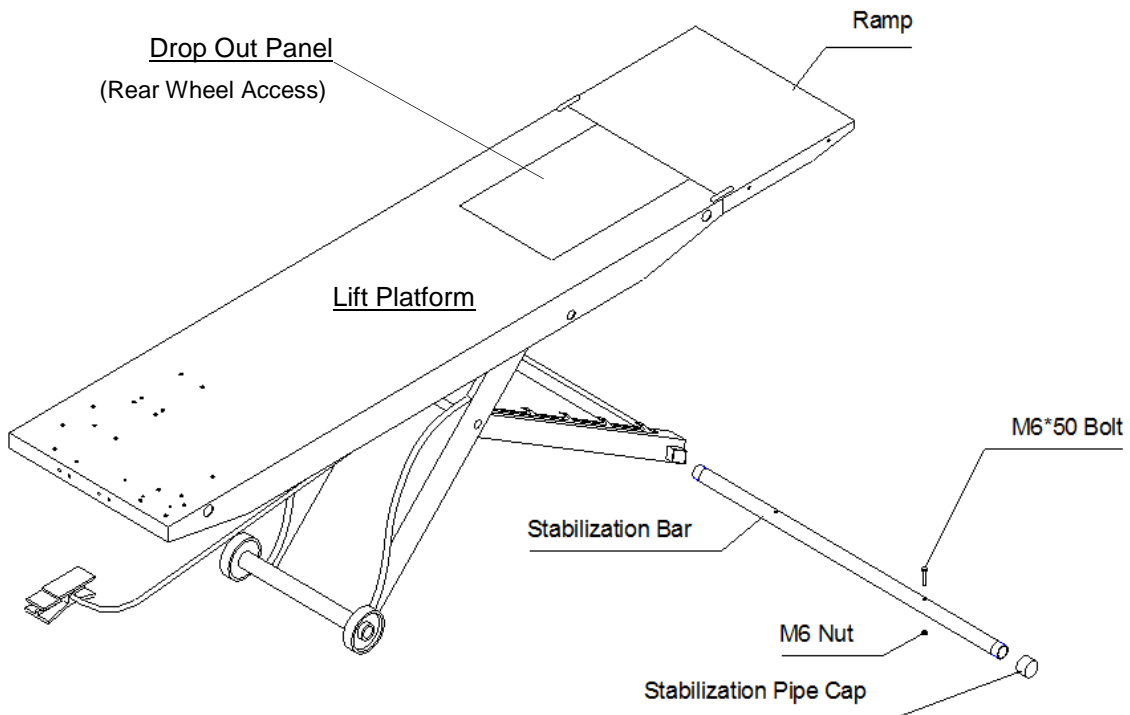

OPERATION & SAFETY INSTRUCTIONS



Loads must be centered on platform at all times. Loads also must be firmly positioned and secured to platform at all times.

1. Only trained persons should operate lift.
2. Center load on platform, not to exceed the 1,000 lbs. maximum weight capacity.
3. Connect to 100 psi maximum shop air to quick disconnect fitting on Foot Valve.



The lift may be damaged and/or personal injury may result if the pressure exceeds the maximum 100 psi rating.

4. To RAISE depress the 'UP' end of Foot Valve. To LOWER depress the 'DOWN' end of Foot Valve. To STOP air flow, position Foot Valve to be level. Once the desired working height is obtained, always lower lift to rest in the locked & secured position.



5. Keep safety latch bar in locked position at all times, except when raising & lowering.



6. Keep hands and tools from under platform and scissor floor path.
7. Lift must be in the fully lowered position when moving to different locations.
8. The working area should be sufficient to lift motorcycles & power sport vehicles.
9. Foot Valve controller should be positioned at least 3 feet away from Motorcycle Lift during raising and lowering operation.
10. Lift is recommended for indoor use only.

MAINTENANCE

1. All moving parts have been lubricated at the factory and should be re-lubricated every (6) months to prevent premature pivot shaft defects. (*Note: Grease zerks are located at each end of frame pivot shaft and at top ends of inside frame assembly.*)
2. Lightly oil cylinder rod when it becomes dry.
3. Squirt small amounts of oil through air bleed hole in plate end of cylinder to lubricate piston and its seal every (6) months.
4. Pivot shaft set screws should be checked frequently to be sure they are tight. (*These are located at the top end of the inside frame assembly.*)

OPTIONAL ACCESSORIES

- **SIDE EXTENSION SET** – Expands width of lift from 24" to 48" includes stabilizer bar.
- **FRONT EXTENSION** – Extends lift top to 93" for longer wheel base motorcycles.
- **CYCLE VISE** – Used to assist in stabilizing motorcycle while on lift, when using tie-downs.

EXPLODED VIEW & PARTS LIST

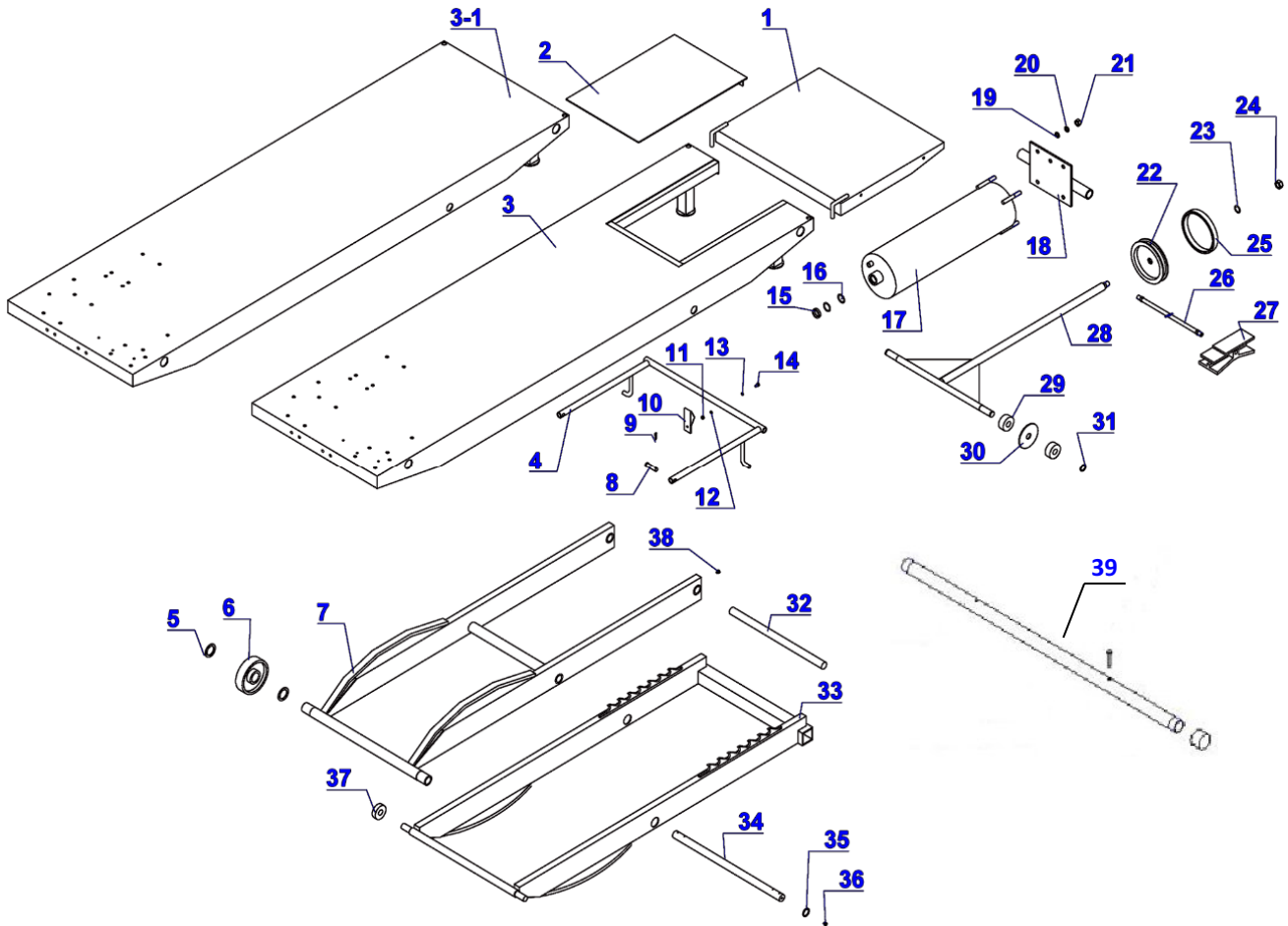

ITEM	DESCRIPTION	QTY
1	Ramp	1
2	Drop out cover	1
3	Top assembly	1
3-1	Top assembly	1
4	Detent bar	1
5	Retaining ring	4
6	Wheel	2
7	Scissor frame A	1
8	Clevis pin	2
9	Cotter pin	2
10	Detent clip	1
11	Nut	1
12	Washer	1
13	Lockwasher	1
14	Screw	1
15	Wiper ring	1
*16	O-ring	2
17	Cylinder	1
18	Cylinder end plate	1
19	Washer	4

* Easily Worn Parts

ITEM	DESCRIPTION	QTY
20	Lockwasher	4
21	Nut	4
22	Piston	1
*23	O-ring	1
24	Nut	1
25	Piston seal	1
26	Valve hose w/fitting	1
27	Foot valve assembly	1
28	Cylinder shaft assembly	1
29	Cam roller bearing	4
30	Cam bearing space	2
31	Retain ring	2
32	Cylinder pivot shaft	1
33	Scissor frame B	1
34	Frame pivot shaft	1
35	Retaining ring	2
36	Oil cup	4
37	Track roller bearing	2
38	Screw	2
39	Stabilizer Bar Assy.	1

OPTIONAL ACCESSORIES INSTALLATION

SIDE EXTENSION SET

- Insert pipes from extension panel package through holes in lift platform. Long pipe mounts to the front and the short pipe mount to the rear.
- Insert M8 wing bolt provided through holes on the underside platform to secure end of pipe to platform.
- Mount side extension panels on ends of pipe for each side of platform, with ramp mount holes to the rear of lift.
- Secure side extension panels to pipe extensions using the provided ring clips.
- Secure side extension ramps to the center ramp with nuts & bolts provided. Ensure ramp holes are positioned towards the center ramp.
- Install stabilization bar by removing the cap at one end, then insert bar through square hole in base of scissor mechanism. Secure with nut & bolt hardware and reinstall cap.

SIDE EXTENSION SET (INSTALLATION DIAGRAM & PARTS LIST)

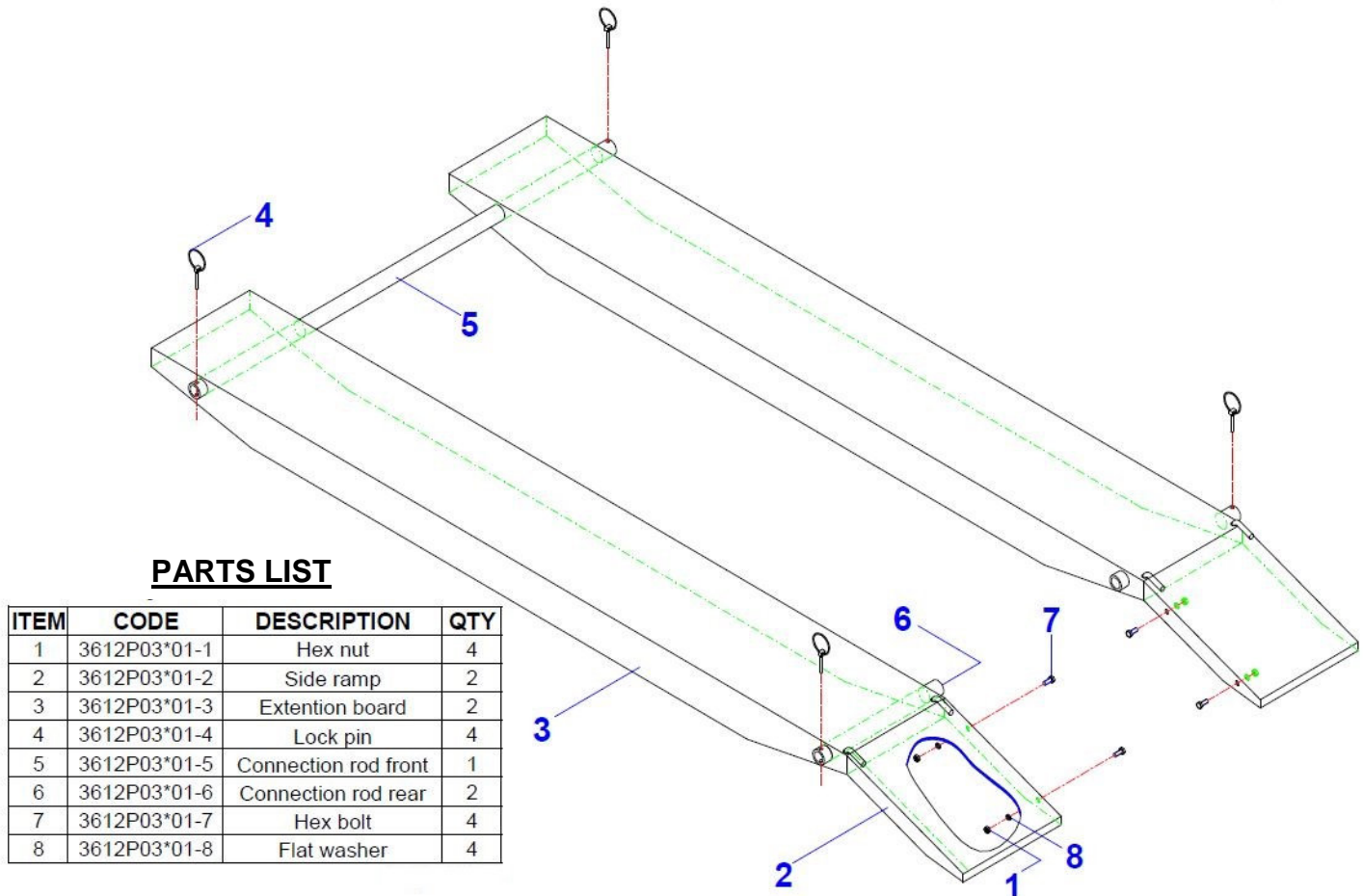

CYCLE VISE

(NOTE: INSTALLATION INFORMATION LOCATED INSIDE VICE PACKAGING)

SIDE EXTENSION SET **(FINAL INSTALLATION DIAGRAM)**

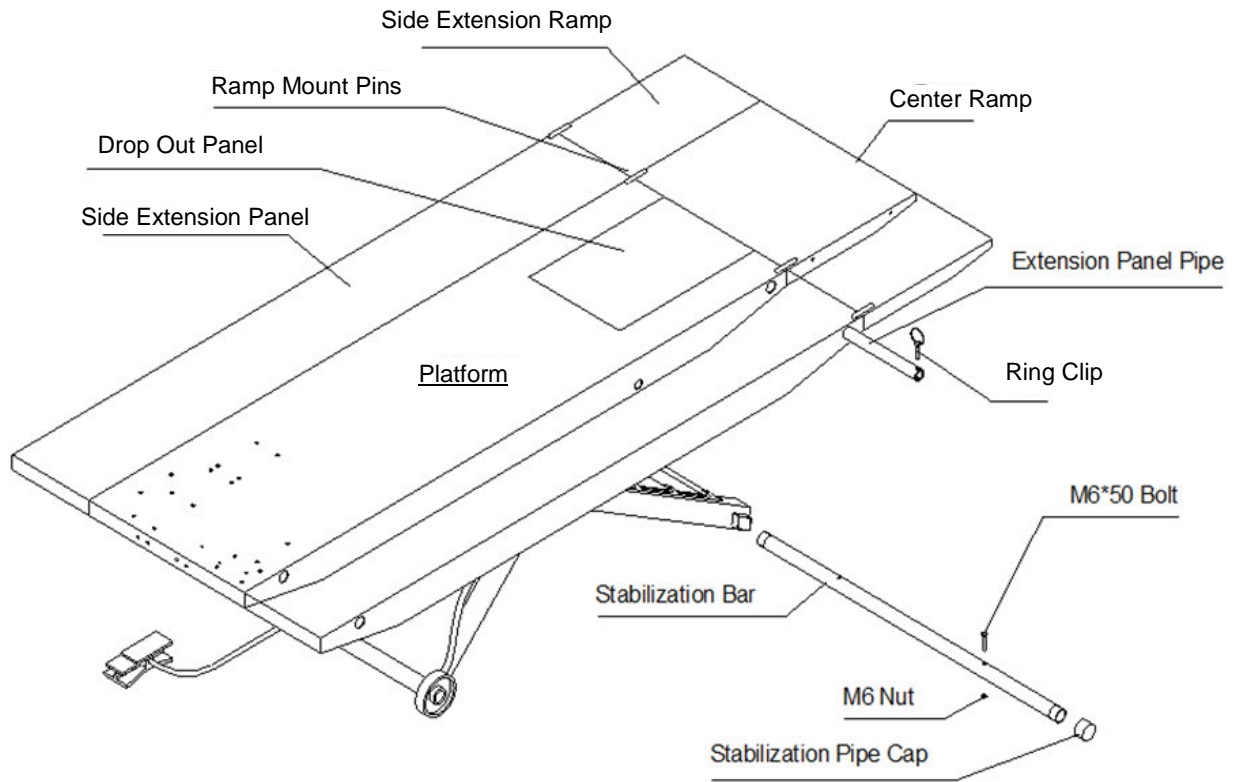

13" FRONT EXTENSION **(INSTALLATION DIAGRAM)**

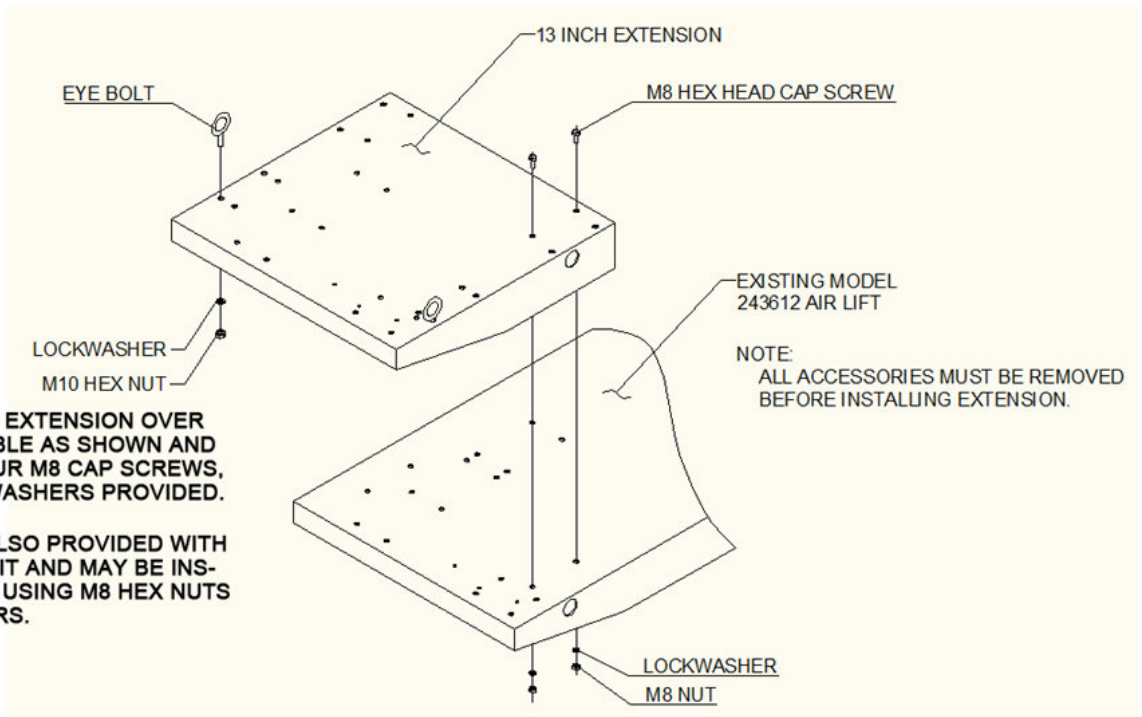

POSITION THE 13" EXTENSION OVER THE EXISTING TABLE AS SHOWN AND ATTACH WITH FOUR M8 CAP SCREWS, NUTS AND LOCKWASHERS PROVIDED.

EYE BOLTS ARE ALSO PROVIDED WITH THE EXTENSION KIT AND MAY BE INSTALLED AS SHOWN USING M8 HEX NUTS AND LOCKWASHERS.

LIMITED WARRANTY

Structural Warranty:

The following parts and structural components carry a five year warranty:

Columns	Arms	Uprights	Swivel Pins
Legs	Carriages	Overhead Beam	
Tracks	Cross Rails	Top Rail Beam	

Limited One-Year Warranty:

Tuxedo Distributors, LLC (Tuxedo) offers a limited one-year warranty to the original purchaser of Lifts and Wheel Service equipment in the United States and Canada. Tuxedo will replace, without charge, any part found defective in materials or workmanship under normal use, for a period of one year after purchase. The purchaser is responsible for all shipping charges. This warranty does not apply to equipment that has been improperly installed or altered or that has not been operated or maintained according to specifications.

Other Limitations:

This warranty does not cover:

1. Parts needed for normal maintenance
2. Wear parts, including but not limited to cables, slider blocks, chains, rubber pads and pulleys
3. Replacement of lift and tire changer cylinders after the first 30 days. A seal kit and installation instructions will be sent for repairs thereafter.
4. On-site labor

Upon receipt, the customer must visually inspect the equipment for any potential freight damage before signing clear on the shipping receipt. Freight damage is not considered a warranty issue and therefore must be noted for any potential recovery with the shipping company.

The customer is required to notify Tuxedo of any missing parts within 72 hours. Timely notification must be received to be covered under warranty.

Tuxedo will replace any defective part under warranty at no charge as soon as such parts become available from the manufacturer. No guarantee is given as to the immediate availability of replacement parts.

Tuxedo reserves the right to make improvements and/or design changes to its lifts without any obligation to previously sold, assembled or fabricated equipment.

There is no other express warranty on the Tuxedo lifts and this warranty is exclusive of and in lieu of all other warranties, expressed or implied, including all warranties of merchantability and fitness for a particular purpose.

To the fullest extent allowed by law, Tuxedo shall not be liable for loss of use, cost of cover, lost profits, inconvenience, lost time, commercial loss or other incidental or consequential damages.

This Limited Warranty is granted to the original purchaser only and is not transferable or assignable.

Some states do not allow exclusion or limitation of consequential damages or how long an implied warranty lasts, so the above limitations and exclusions may not apply. This warranty gives you specific legal rights and you may have other rights, which may vary from state to state.

1905 N Main St Suite C, Cleburne, TX 76033
Ph. 817-558-9337 / Fax 817-558-9740