

**PRO 11000C-DX**  
**Two-Post Clear Floor**  
**'Bi-Symmetric' Automotive Lift**

**11,000 lb. Capacity**  
(2,750 lbs. Max per Arm)



**Installation & Operation Manual**

Jun 2017

# TABLE OF CONTENTS

## **1. Safety Information**

- 1.1 Note, Caution and Warning
- 1.2 Important Information
- 1.3 Safety Instructions

## **2. Technical Manual**

- 2.1 Product Description
- 2.2 Technical Data

## **3. Installation**

- 3.1 Site Selection
- 3.2 Surface Condition/ Foundation & Anchoring
- 3.3 Tools Required
- 3.4 Installation Procedure
- 3.5 Hydraulic Scheme

## **4. Operation**

- 4.1 Operation Instructions
  - 4.1.1 Lift Preparation
  - 4.1.2 Loading Lift
  - 4.1.3 To Raise Lift
  - 4.1.4 While Using Lift
  - 4.1.5 To Lower Lift
  - 4.1.6 Unloading Lift
- 4.2 Maintenance Instructions

## **5. Exploded View / Parts List**

## **6. Troubleshooting Guide**

## **7. Power Unit Priming**

## **8. Warranty Policy**

# 1. Safety Information

## 1.1 Note, Caution and Warning

This document uses the following terms - **NOTE**, **CAUTION** and **WARNING** - to alert you to special instructions, tips, or hazards for a given procedure. Please familiarize yourself with the notations described below.

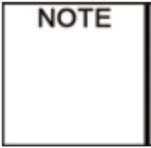

INDICATES IMPORTANT INFORMATION THAT REQUIRES SPECIAL ATTENTION, SUCH AS A PROCEDURE FOR A SPECIFIC VEHICLE, OR TIPS ON OPERATING THE EQUIPMENT.



INDICATES THE POTENTIAL FOR DAMAGE TO EQUIPMENT, ACCESSORIES, OR THE VEHICLE UNLESS YOU FOLLOW THE INSTRUCTIONS OR PROCEDURE EXACTLY.



INDICATES THE POTENTIAL FOR PROPERTY DAMAGE, PERSONAL INJURY, OR DEATH DUE TO HAZARDS ASSOCIATED WITH THE EQUIPMENT, VEHICLE, OR ENVIRONMENT. DO NOT PERFORM ANY PROCEDURE UNTIL YOU HAVE READ AND UNDERSTOOD THE WARNING INSTRUCTIONS.

## 1.2 Important Information

1. Read this manual thoroughly before **installing, operating, or maintaining this lift**.
2. This lift is designed for indoor use only, and **should not** be installed in a pit or depression.
3. The floor on which the lift is to be installed must be **4-1/4" minimum thickness concrete, with a minimum compressive strength of 3,000 psi**.
4. The lift has **specific electrical requirements** as described in the Installation Instructions section of this manual.
5. This lift has a **minimum ceiling height requirement** as described in the Installation Instructions section of this manual.
6. Failure by the owner to provide the **recommended shelter, mounting surface, electrical supply, and ceiling height** could result in unsatisfactory lift performance, property damage, or personal injury.
7. The operation of the lift is permitted by authorized personnel only.

### 1.3 Safety Instructions

1. **Do not** raise a vehicle on the lift until the installation is completed as described in this manual.
2. Technicians should be trained to use and care for the lift by familiarizing themselves with this instruction manual. **The lift should never be operated by an untrained person.**
3. Always position the arms and adapters properly out of the way before pulling the vehicle into, or out of the bay. Failure to do so could damage the vehicle and/or the lift.
4. **Do not overload the lift.** The capacity of the lift is shown on cover of this document and on the lift's serial number tag.
5. Positioning the vehicle is very important. Only trained technicians should position the vehicle on the lift. **Never allow anyone to stand in the path of the vehicle as it is being positioned and never raise vehicle with passengers inside.**
6. Position the arms to the vehicle manufacturer's recommended pickup points. Raise the lift until contact is made with the vehicle. Make sure that the arms have properly engaged the vehicle before raising the lift to a working height.
7. Keep everyone clear of the lift when the lift is moving, the locking mechanism is disengaged, or the vehicle is in danger of falling.
8. Unauthorized personnel should never be in the shop area when the lift is in use.
9. Inspect the lift daily. **The lift should never be operated if it has damaged components, or is malfunctioning.** Only qualified technicians should service the lift. **Replace damaged components with manufacturer's parts, or equivalent.**
10. **Keep the area around the lift clear of obstacles.**
11. **Never override the self-returning lift controls.**
12. Use safety stands when removing or installing heavy vehicle components.
13. Avoid excessive rocking of the vehicle when it is on the lift.
14. To reduce the risk of personal injury, keep hair, loose clothing, fingers, and all body parts away from moving parts.
15. To reduce the risk of electric shock, do not use the lift when wet, do not expose the lift to rain.

16. To reduce the risk of fire, do not operate equipment in the vicinity of open containers of flammable liquids.
17. Use the lift only as described in this manual, **use only manufacturer's recommended attachments.**
18. **Unusual vehicles, such as limousines, RV's, and long wheelbase vehicles, may not be suitable for lifting on this equipment.** If necessary, consult with the manufacturer or the manufacturer's representative.
19. The troubleshooting and maintenance procedures described in this manual can be done by the lift's owner/employer. Any other procedure should only be performed by trained lift service personnel. **These restricted procedures include, but are not limited to, the following: cylinder replacement, carriage and safety latch replacement, column replacement and overhead structure replacement.**
20. Anyone who will be in the vicinity of the lift when it is in use should familiarize themselves with the following **Caution, Warning, and Safety** related decals supplied with this lift, and replace them if they are illegible or missing.

## 2. Technical Manual

### 2.1 Product Description

The TP11KC-DX (165948T) 2-post hydraulic lift is a surface mounted, frame contact lift incorporating the latest safety technologies. Designed and manufactured for a lifting capacity of 11,000 lbs. (Max 2,750 lbs. per Lifting Arm) and is fully capable for lifting vehicles, vans and light trucks by safely holding them in an elevated position. The TP11KC-DX also incorporates the *Bi-Symmetric* feature, which allows the Arms to be configured for both asymmetrical & symmetrical lifting configurations.

The TP11KC-DX 2-post hydraulic lift consists of a fixed structural unit (Crossbeam and Columns), the mobile units (Carriages and Lift Arms), and the Hydraulic Power System and Safety devices.

- A. Crossbeam
- B. Column
- C. Carriage
- D. Lifting Arm
- E. Power Unit
- F. Overhead Safety Shut-Off Bar
- G. Single Point Safety-Latch Release

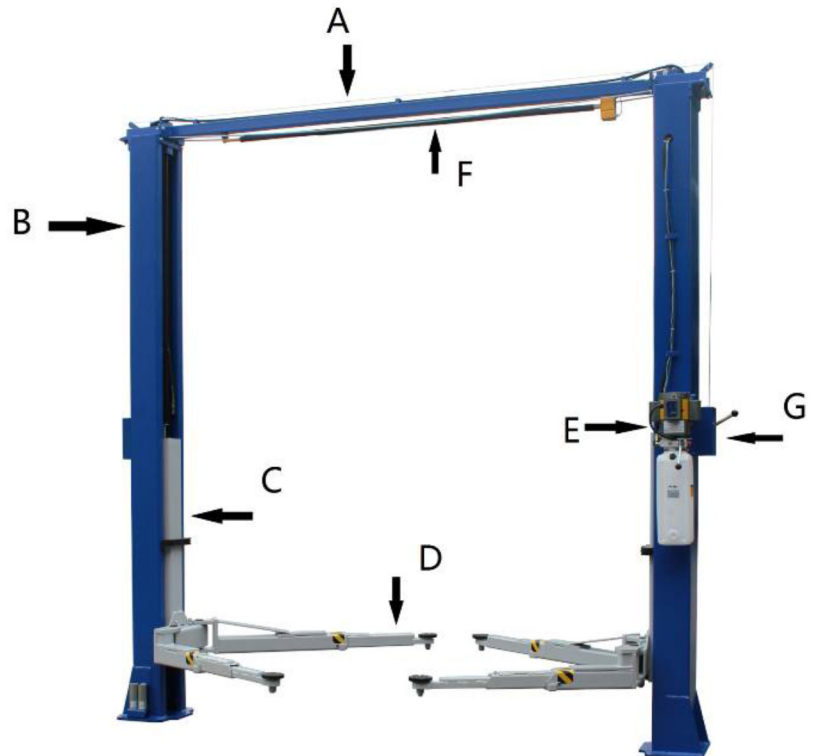

### 2.2 Technical Data

Capacity	11,000 lbs. (Max 2,750 lbs. per Arm)
Height Overall	144"
Width Overall w/ Power Unit	145-1/2"
Max Lifting Height	71"
Max Lifting Height w/ Tallest Adaptor	76-1/2"
Width Between Columns	116"
Min Pad Height	4"
Drive Thru Clearance	104"
Front Arm Reach – Min / Max	23" – 45"
Rear Arm Reach – Min / Max	41" – 57"
Power	220V, 20 Amp, 1 Phase

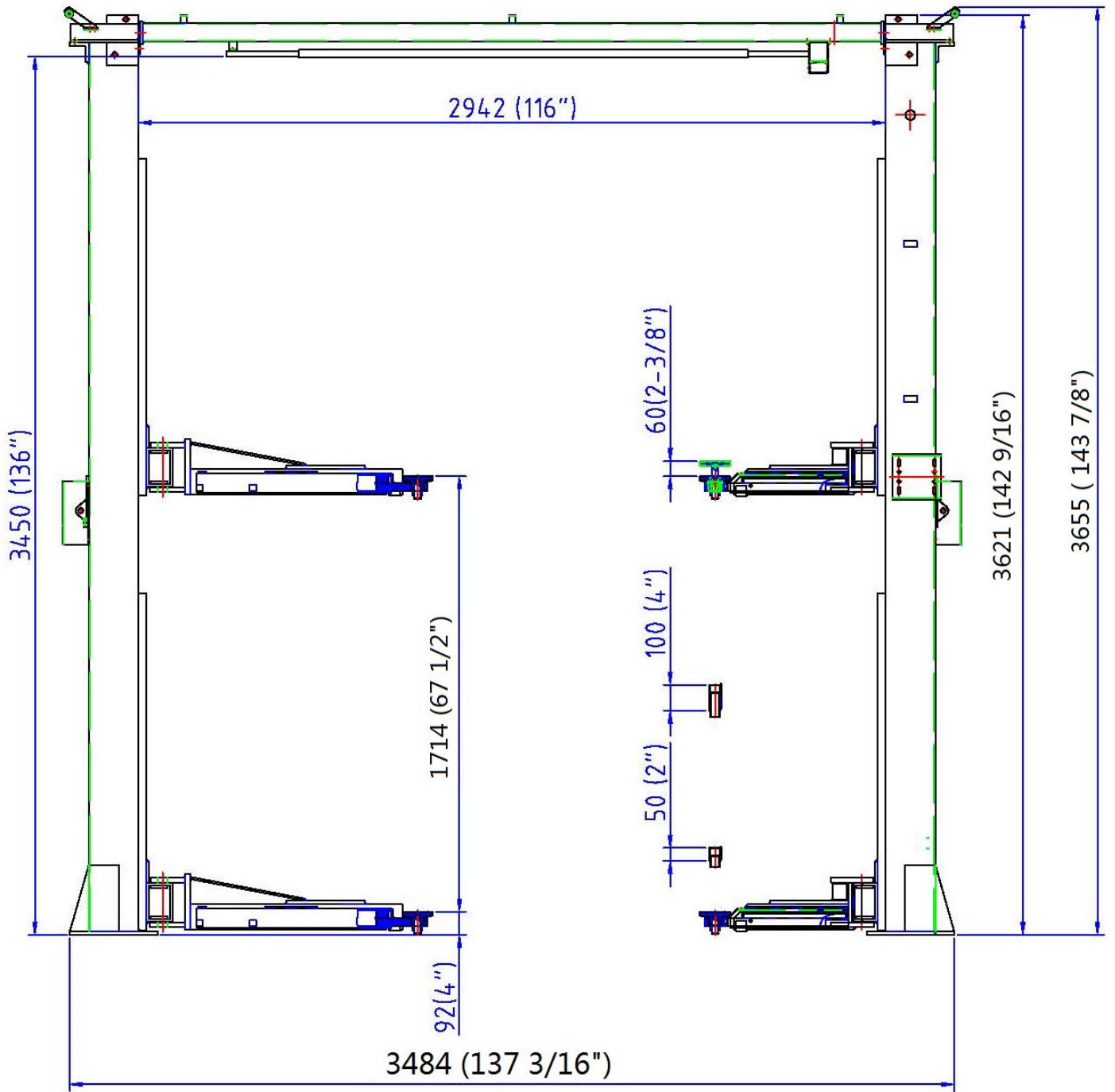

Fig. 1 – Front View Spec.



**POWER UNIT MUST BE INSTALLED ON THE PASSENGER SIDE. FAILURE TO DO SO CAN RESULT WITH INTERFERECE BETWEEN THE POWER UNIT AND SHORT SWING ARM, THUS CAUSING DAMAGE TO POWER UNIT.**

## Bi-Symmetric (Asymmetric & Symmetric) Configurations

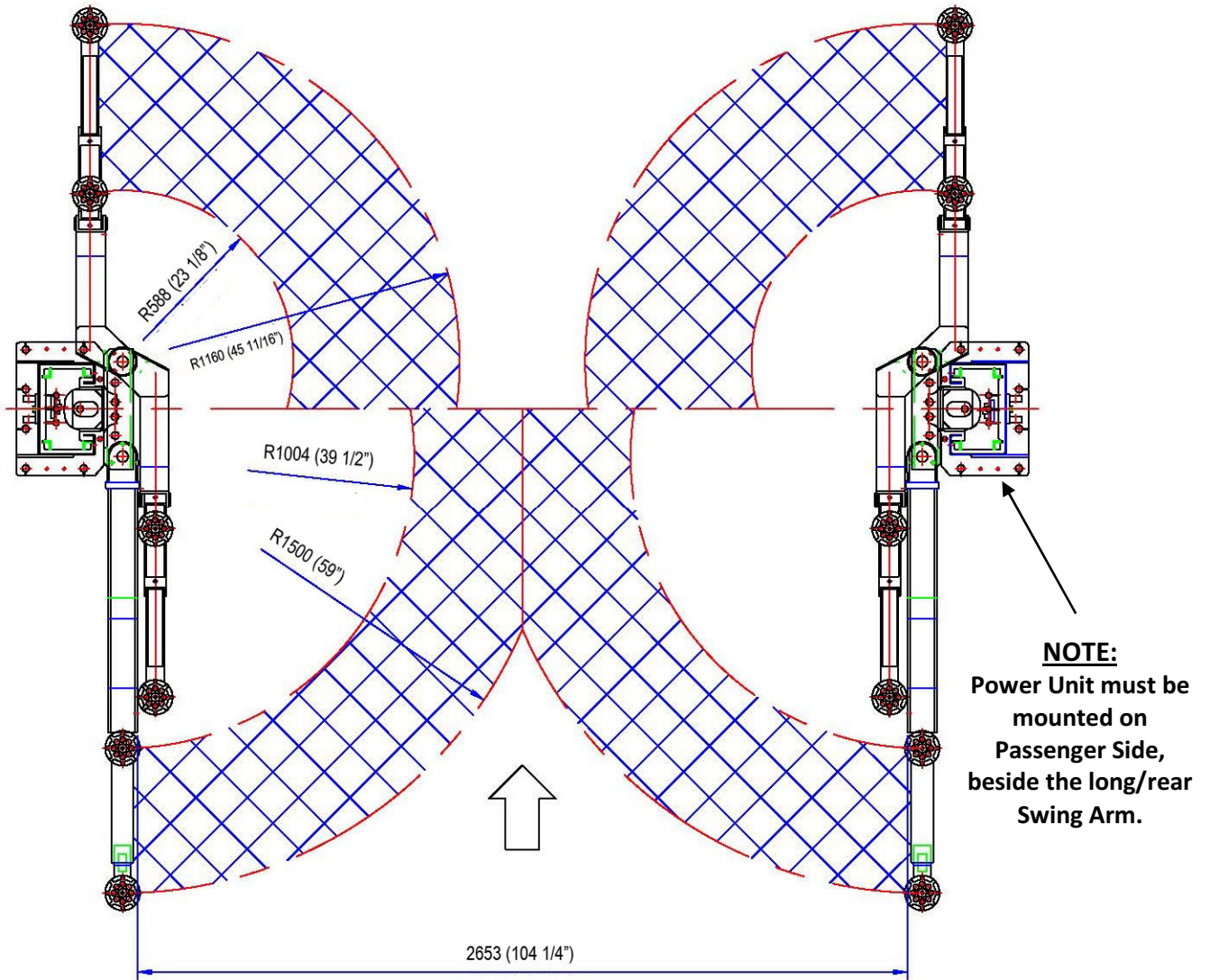

Fig.2a –Top View Spec.

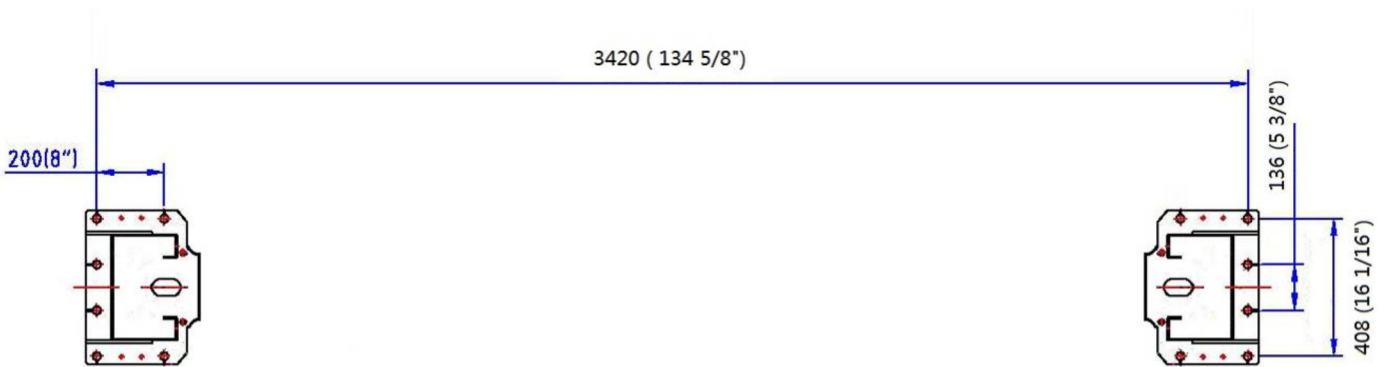

Fig.2b - Base Size Spec.



## 3. Installation

### 3.1 Site Selection

The hydraulic lift is designed only for indoor use. Application in a room with explosion hazard is not permitted. Setting in a wet place, a car wash center for instance, is prohibited.

### 3.2 Surface Condition / Foundation & Anchoring

The 2-post hydraulic lift should be installed on level ground. The foundation must be 4-1/4" minimum thickness concrete, with a minimum compressive strength of 3,000 psi. Failure to meet the foundation requirement may cause the lift instability or personal injury. Installing on asphalt, soft clay floor or near the expansion gap is prohibited.

## FOUNDATION and ANCHORING REQUIREMENTS

1. Concrete shall have compression strength of at least 3,000 PSI and a minimum thickness of 4-1/4" in order to achieve a minimum anchor embedment of 3-1/4". NOTE: When using the standard supplied 3/4" x 5-1/2" long anchors, if the top of the anchor exceeds 2-1/4" above the floor grade, you DO NOT have enough embedment.
2. Maintain a 6" minimum distance from any slab edge or seam. Hole to hole spacing should be a minimum 6-1/2" in any direction. Hole depth should be a minimum of 4-1/4".
3. DO NOT install on asphalt or other similar unstable surface. Columns are supported only by anchoring to floor.
4. Using the horseshoe shims provided, shim each column base as required until each column is plumb. If one column has to be elevated to match the plane of the other column, full size base shim plates should be used. Torque anchors to 130 ft-lbs. Shim thickness MUST NOT exceed 1/2" when using the 5-1/2" long anchors provided with the lift.
5. If anchors do not tighten to 130 ft-lbs. installation torque, replace the concrete under each column base with a 4' x 4' x 6" thick 3,000 PSI minimum concrete pad keyed under and flush with the top of existing floor. Allow concrete to cure before installing lifts and anchors (typically 2 to 3 weeks).

## ANCHORING TIPS

1. Use a concrete hammer drill with a carbide tip, solid drill bit the same diameter as the anchor, 3/4" - (.775 to .787 inches diameter). Do not use excessively worn bits or bits which have been incorrectly sharpened.
2. Keep the drill in a perpendicular line while drilling.
3. Let the drill do the work. Do not apply excessive pressure. Lift the drill up and down occasionally to remove residue to reduce binding.
4. Drill the hole to depth of 2" deeper than the length of anchor. NOTE: Drilling thru concrete (recommended) will allow the anchor to be driven thru the bottom of foundation if the threads are damaged or if the lift will need to be relocated.
5. For better holding power blow dust from the hole.
6. Place a flat washer and hex nut over threaded end of anchor, leaving the nut almost flush with the top of the anchor bolt. Carefully tap anchor into hole. Do not damage threads. Tap anchor into the concrete until nut and flat washer are against base plate. Do not use an impact wrench to tighten! Tighten the nut, two or three turns on average after the concrete has cured (28-day cure). If the concrete is very hard only one or two turns may be required.

## FOUNDATION and ANCHORING REQUIREMENTS, Fig 3

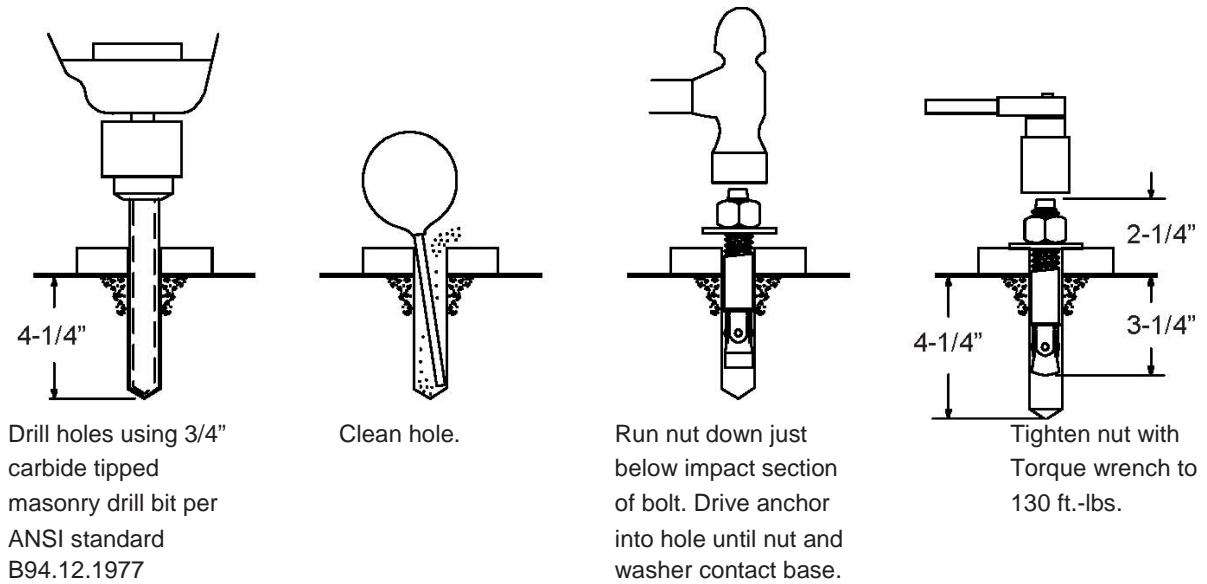

### 3.3 Tools & Equipment Required

- 12 quarts of Non-Detergent / Non-Foaming Hydraulic Oil - SAE-10, AW 32 or equivalent
- Chalk line and 12' Tape Measure
- Concrete hammer drill with 3/4" bit
- 11/16" open end wrench
- 3/4" open end wrench
- Torque wrench
- 15/16" deep socket or wrench
- 1-1/8" socket
- 13/16" open end wrench
- Level (18" minimum length)
- Vise grips
- Tape measure
- Funnel
- Hoist or Forklift (optional)
- Two 12' step ladders
- 1/4" drive ratchet with 5/16" socket

### 3.4 Installation Procedure

1. Read this manual thoroughly before installing, operating, or maintaining this lift.
2. Site Evaluation and Lift Location:
  - A. Always use an architect's plan when provided. Before unpacking the lift entirely, determine if the site is adequate for the lift model being installed see figures 1 & 2 for typical bay layout and ceiling height requirements.
  - B. Snap chalk lines to identify the lift's centerline.
  - C. Snap a chalk line parallel to the lift's centerline, **spaced 9.00"** (230 mm) toward the rear of the bay. This line represents the back edge of the column bases.
  - D. Snap chalk lines parallel to the lift's centerline **spaced 68-7/8"** (1,750 mm) **to the left and 68-7/8"** (1,750 mm) **to the right**. These lines represent the **APPROXIMATE** outside edges of the column bases.



**DO NOT USE THESE LINES TO POSITION THE COLUMNS, FOLLOW THE INSTRUCTIONS IN THIS MANUAL.**

3. Unpack the lift. Remove the swing arms, bolt box, power unit box, and overhead beam.
  - A. **Save all packing hardware**, as these components **are necessary to complete** the installation.
  - B. **Remove the 1/2"** bolts from the uprights which hold the two columns together.
  - C. **Remove the upper column.** **Do not stand the columns up** now but lay the columns with their flat backs on the floor.
4. Attach the cylinder mounts (uprights) using 4ea 1/2" x 1-3/4" bolts, washers and nuts provided as shown in figure 4a & 4b.

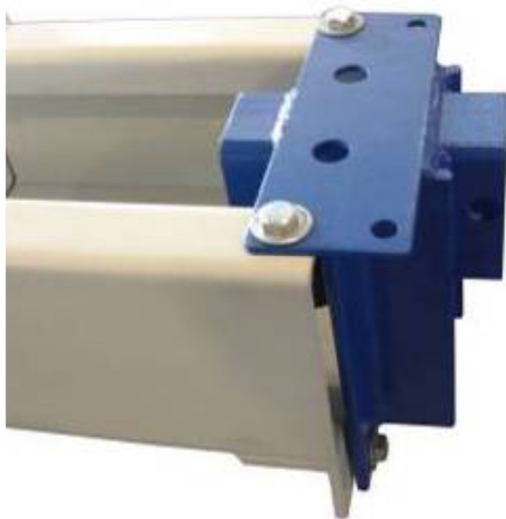

**Fig. 4a**

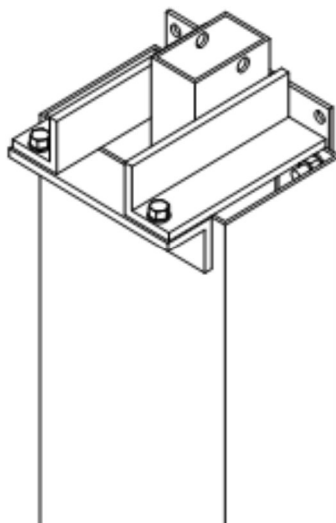

**Fig. 4b**

## 5. Install Hydraulic Cylinders

- A. Install the cylinder to the cylinder mounts (uprights) with **9/16" x 4-1/2" pins, cylinder bushings (spacer) washers, and snap rings, as in figure 5a**. The hose connecting port near the other end of the cylinder should be positioned pointing to the column's opening. (Fig. 5b)
- B. Bolt the cylinder rods to the carriages. (Fig. 5c) NOTE: Make sure snap ring on cylinder rod is in groove.



Fig. 5a



Fig. 5b



Fig. 5c

**DO NOT HOLD THE CYLINDER ROD IN A WAY THAT COULD DAMAGE THE FINISH. CYLINDER LEAKS CAUSED BY DAMAGED RODS ARE NOT COVERED UNDER WARRANTY.**

## 6. Columns Positioning & Main Side Column Anchoring

- A. **Carefully stand up the Main side column (w/ power unit bracket) & Off side column**, position the columns where they are to be secured. Ensure column's openings are facing each other.



**The Main side column must be positioned to be on the Passenger side or right side with the vehicle headed forward. The distance between column back edge to wall, should be at least 2 feet for safety.**

- B. Using the column base as a template, drill the anchor bolt holes for the **Main side column Only!** (Refer to FOUNDATION REQUIREMENTS & ANCHORING TIPS ON PAGES 9 & 10)  
**NOTE: DO NOT ANCHOR OFF SIDE COLUMN AT THIS TIME!**
- C. Install the anchor bolts, assemble washers & nuts onto the anchor bolts. Thread the nuts onto the anchor bolts where the tops of the nuts are just above the top of the anchor bolts. Carefully tap the anchor bolts into the concrete until the washer rests against the base plate. **Ensure not to damage threads.**
- D. Using a level, plumb the Main side column both side to side and front to back. Shim the leg as necessary using the Shims provided. Tighten anchor bolts to 130 ft. lbs. as noted on page 9. Re-check plumbness.  
**NOTE: Refer to FOUNDATION & ANCHOR REQUIREMENTS if more than 1/2" of shims are required.**
- E. Ensure Off side column is in the correct location. **DO NOT DRILL HOLES FOR ANCHORS at this time.**

## 7. Overhead Limit Switch & Overhead Beam (Fig. 6a, 6b & 6c)

- A. Install overhead limit switch assembly to overhead beam, using 2ea 1/4"-20 Bolt & Lock Nuts as shown in figs 6a, 6b & 6c.
- B. Slide end of padded bar (without a mounting hole) through the slot in the overhead switch assembly. Connect the padded bar to the inside hole in the overhead beam using a spacer and 1/4"-20 Bolt & Lock Nut

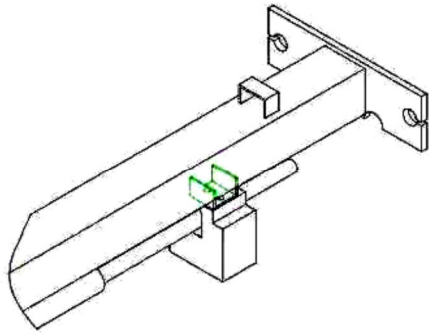

Fig. 6a

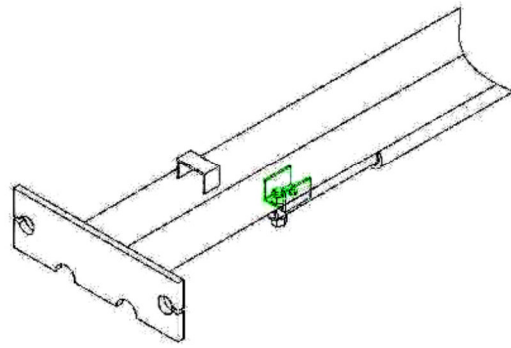

Fig. 6b



Fig. 6c

8. Install overhead beam to cylinder mounts (uprights) using 2ea 1/2" x 1-3/4" bolts, washers & nuts on each end, (Figs. 7a, 7b, 7c). **NOTE:** Ensure overhead Limit Switch Assembly is on the Main side column side.

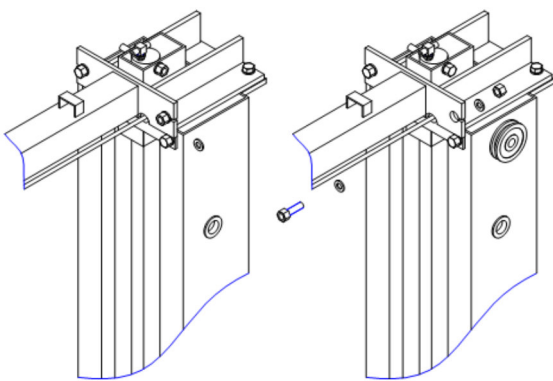

Fig. 7a



Fig. 7b



**Fig. 7c**

**9. Anchoring Off Side Column**

- A. Using a level, check the alignment and plumbness of the entire structure. Plumb the off side column both side to side and front to back.
- B. The base of the column may vary from the preliminary layout, as it is more important that the column be perpendicular to the floor and parallel to the other column.
- C. Install the anchor bolts and shim the base as described in Step #6

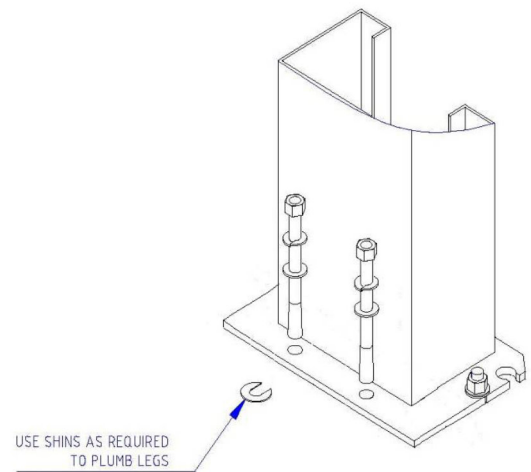

**10. Equalization Cable Routing**

- A. The carriages should be resting on the same column latches for proper equalization. Ensure to measure the height above the baseplate to each carriage. The measurement should be within 3/8" of each other.

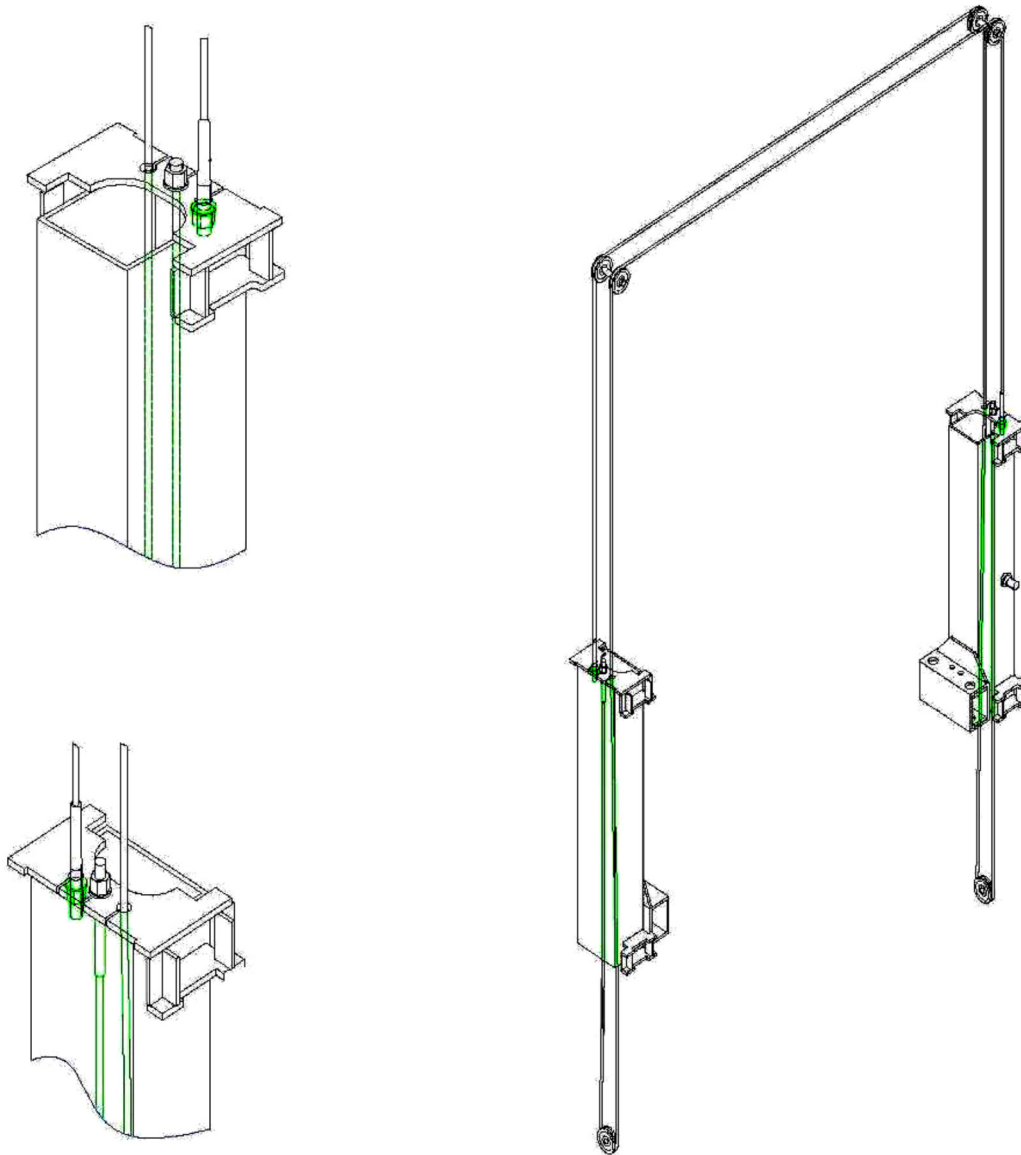

**Fig. 8a**



**Fig. 8b**

- B. Using the diagrams, rout the equalization cables according to Fig. 8a, 8b, 8c from carriage to carriage through the cable rollers. Secure to carriages using Nylon Hex Nuts & Washers. Ensure that cables are not crossed together. Take out slack but **DO NOT TIGHTEN CABLES AT THIS TIME.**
- C. After equalizations cables are routed and connected to carriages, take out the slack in both cables by turning down the nuts on top of each carriage top. Use vise grips to hold the cable end, but be very careful not to damage the threads.
- NOTE: CARRIAGES MUST REMAIN AT THE SAME COLUMN LOCK HEIGHT POSITION WHILE CABLES ARE BEING TIGHTENED. FAILURE TO DO WILL CAUSE THE CARRIAGES SAFETY LATCHES TO BE OUT OF SYNC.**
- D. Alternately tighten the cable nuts at both carriages until the cables are tightened. The correct tension in the cables are indicated by being able to pull the cables together with approximately 15 lbs. effort at midpoint in the column. If the cables are installed correctly, both carriages will raise together.



**Fig. 8c - Cable Routing**



## 11. Install the Hydraulic Fittings, Hoses and Return Lines

### A. Fitting & Hose Connecting:

1. First screw on the hose fitting connectors on the cylinder's lower end ports. (Fig. 9a)
2. Connect the longest hose from the cylinder in Off side column to the top of Main side column. Remember to route the hose through the hook on cross beam. (Fig. 9b & 9c)
3. Then from the T-fitting inside column, connect the shortest length hose directly down to the main inside cylinder connector. (Fig. 9d)
4. Another middle length hose from the T-fitting goes to the motor pump through a hole on the side of the column. (Fig. 9d)



**Fig. 9a**



**Fig. 9b**



**Fig. 9c**



**Fig 9d**

### B. Return Line Connection (blue air-line)

1. Screw in an elbow air-line fitting on the top end of the off side cylinder (Fig. 9b).
2. Screw in another T air-line fitting on the top end of main side cylinder also. (Fig. 9c)
3. Connect the return line from off side cylinder to main side cylinder through fittings.



## 12. Mounting of the Power Unit

- A. Mount on the motor pump using 5/16" x 1-1/4" bolts and nylon nuts provided in the bolt box to Main side column.
- B. Connect the hose and the 'blue' Return Line to the pump valve block as shown in ( Fig 10)

## 13. Latch-release cable wiring and accessories mounting.

- A. Mount the safety latch device on each column as shown in ( Fig. 11a & 11b)



Fig. 10

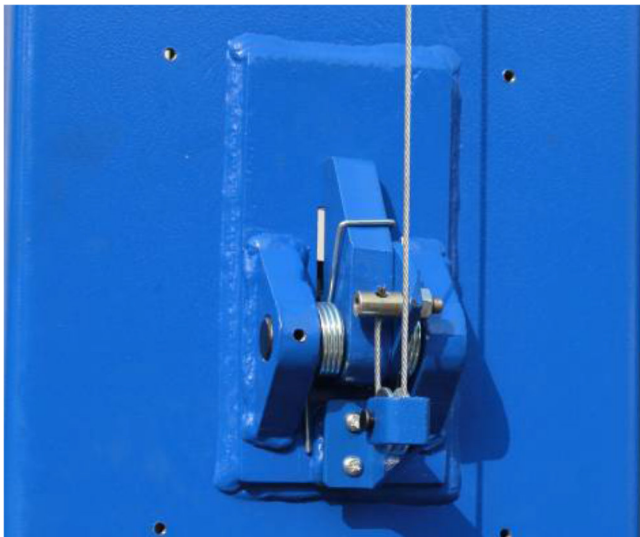

Fig. 11a



Fig. 11b

B. Mount the Cable Pulley and support bracket on the top of the columns. (Fig. 11c)



**Fig. 11c**

C. Route and adjust the cable tension so that when the handle is pressed down, both latch will be released.

D. Put on the covers of the latch device. (Fig 12a & 12b)



**Fig. 12a**

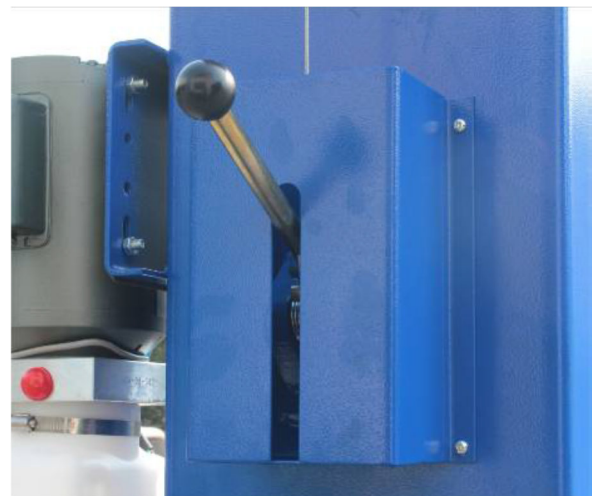

**Fig. 12b**

## 14. Install Lifting Arms

- A. Position the gears with pin against the bottom of the arms in the orientation shown in Fig.13a. Attach the gears to the arms with bolts. Do not tighten at this time.

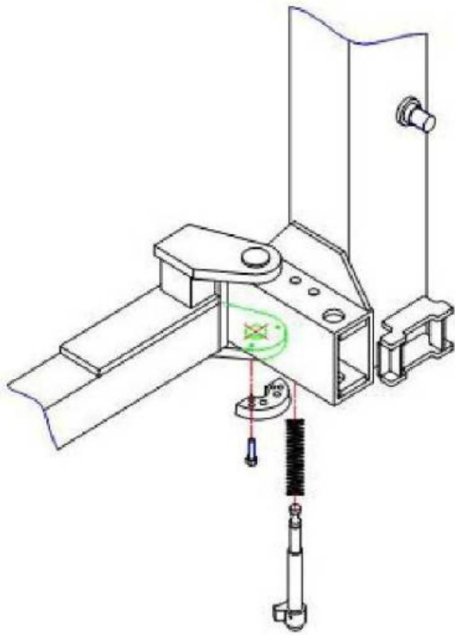

**Fig. 13a**



**Fig. 13b**

- B. Position the restraint pawls on the carriage to mate with the gears on the arms.  
C. Install the swing arms and pins.

### Suggestion:

The longer arms go to the rear or drive in side of the lift, and the short arms go to the front.



**DON'T FORCE THE GEARS, IT MAY BE NECESSARY TO PULL UP ON THE RESTRAINT ACTUATOR PIN IN ORDER TO INSTALL THE SWING ARM PIN.**

- D. Tighten the gear bolts to 30 – 34 ft. lbs.  
E. Assemble the arm extensions and lifting pads. Limit arm extensions with bolts & nuts. ( Figs. 14a & 14b)



**Fig. 14a - Front Arm**

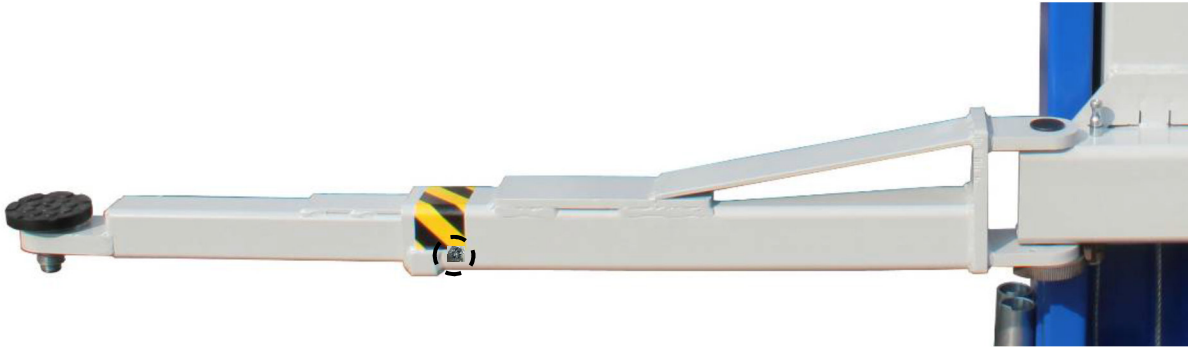

**Fig. 14b - Rear Arm**

**15. Fill the Tank.**

Remove the vent plug from the power unit and fill the reservoir with hydraulic oil. Make sure the funnel used to fill the power unit is clean. Fill with Non-Detergent / Non-Foaming Hydraulic Oil - SAE-10, AW 32 or equivalent. Replace the vent plug. The unit holds approximately ten quarts of fluid.

**16. Lubricate the four inside corners of both columns with heavy duty grease.**

**17. Electrical Connection to POWER UNIT & OVERHEAD LIMIT SWITCH**

- A. Have a certified electrician make the electrical connection to the power unit. Use separate circuit for each power unit, as shown below in the Wiring Diagram.

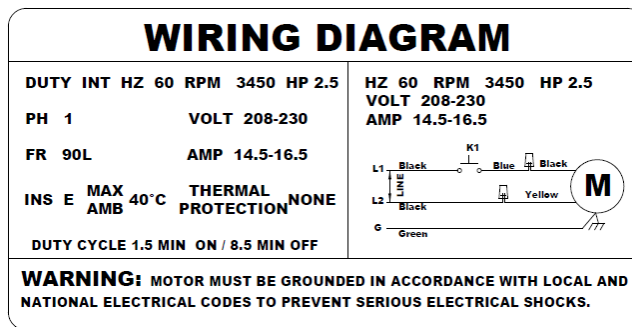

***IMPORTANT!*** The wiring must comply with local code. Protect each circuit with time delay fuse or circuit breaker. For 208V-230V single phase, use 20 amp fuse.

***WARNING!!*** Never operate the motor in line voltage less than 208VAC as motor damage may occur.

- B. Have a certified electrician make the electrical connection for the K2 overhead limit switch to power unit's switch box, as shown below.

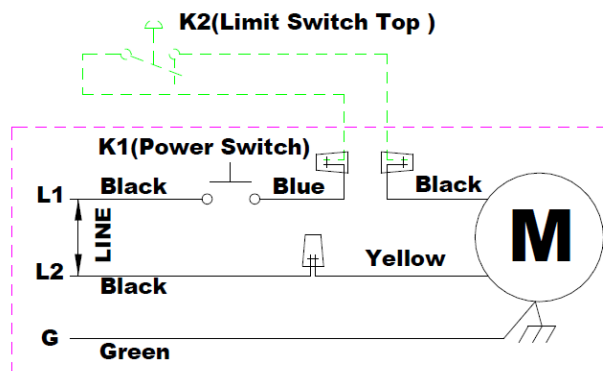

## 18. Testing

**NOTE**

- (1) In this step A, there is no load on the lift.
  - (2) Cycle up and down must be with interval rest of 2 min.
- A. Without a load, raise the lift empty to the top of its travel and lower it to the floor three (3) times to remove the remaining air from the hydraulic system.

**(IF POWER UNIT RUNS FINE BUT WILL NOT PUMP, SEE PAGE 32 FOR PRIMING PROCEDURE)**

- B. The latches should click close together as the lift is being raised. If not, adjust the equalization cable by turn the nuts.
- C. When the carriages are lowered onto the locks, the Latch Release Handle should NOT be capable of being pulled down. Prior to lowering down carriages, always raise up enough to free the latches, then pull down the latch release handle to unlock the carriages to lower.
- D. The first time a vehicle is placed on the lift, raise it no higher than three feet. Lower the vehicle onto the safety latches. Raise the lift a few inches and pull latch release lever then lower the vehicle to the floor.
- E. Raise the vehicle to full height and lower the carriages onto the safety latches. Lower the vehicle to the floor.
- F. After cycling the lift ten times with a vehicle on it, recheck the tightness of the anchors to at least 110 ft-lbs.

***Now the lift is ready for operation.***

### 3.5 Hydraulic Scheme

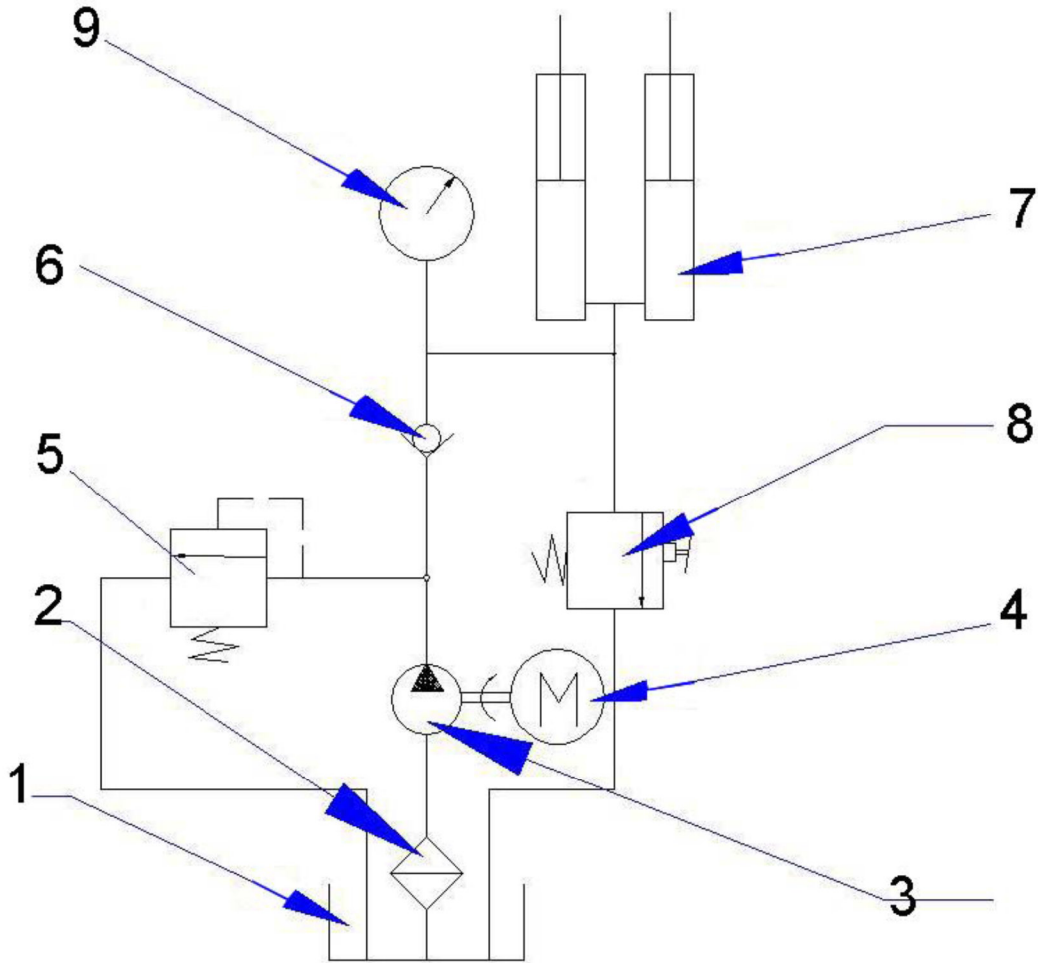

1. Reservoir Tank	2. Mesh Filter	3. Gear Pump
4. Motor	5. Relief Valve	6. Check Valve
7. Hydraulic Cylinder(s)	8. Manual Release Valve	9. Pressure Gauge (not supplied)
Motor Power	3 HP @ 2,850 RPM	
Hydraulic Pressure Setting	2,900 PSI	

## 4. Operation

BE SURE TO READ AND FAMILIARIZE YOURSELF WITH THE SAFETY INSTRUCTIONS AT THE BEGINNING OF THIS MANUAL. FAILURE TO FOLLOW SAFETY INSTRUCTIONS MAY RESULT IN PROPERTY DAMAGE, PERSONAL INJURY OR DEATH.

### 4.1 Operating Instructions



BE SURE TO READ AND FAMILIARIZE YOURSELF WITH THE SAFETY INSTRUCTIONS AT THE BEGINNING OF THIS MANUAL. FAILURE TO FOLLOW SAFETY INSTRUCTIONS MAY RESULT IN PROPER DAMAGE, PERSONAL INJURY OR DEATH.



TO AVOID PERSONAL INJURY AND/OR PROPERTY DAMAGE, PERMIT ONLY TRAINED PERSONNEL TO OPERATE LIFT. AFTER REVIEWING THESE INSTRUCTIONS, GET FAMILIAR WITH LIFT CONTROLS BY RUNNING THE LIFT THROUGH A FEW CYCLES BEFORE LOADING VEHICLE ON THE LIFT.



ALWAYS LIFT THE VEHICLE USING ALL FOUR ADAPTERS. NEVER RAISE JUST ONE END, ONE CORNER, OR ONE SIDE OF VEHICLE.



THE HEAVY END OF THE VEHICLE MUST PUT ON THE SHORT / FRONT / CURVED ARMS.

#### 4.1.1 Lift Preparation

Lift arms must be fully lowered and service bay clear of all personnel before the vehicle be brought into the bay. Swing arms out to full drive-thru position

#### 4.1.2 Loading Lift

Swing arms under vehicle and position adapters at vehicle manufacturer's recommended lift points. Use intermediate, high step, or optional adapters for under body clearance when required.

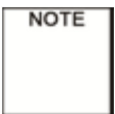

**Typical Lifting Points.** Some Vehicle may have the manufacturer's Service Garage Lift Point locations identified by triangle shape marks on its undercarriage. Also, there may be a label located on the right front door lock face showing specific vehicle lift points. If the specific vehicle lift points are not identified, refer to the vehicle operation manual or consult the vehicle agent. ALWAYS follow the operating instructions supplied with the lift.

#### 4.1.3 To Raise Lift

- a. Push START button of the motor pump.
- b. Stop before arms making contact with vehicle. Check arm restraint pins for engagement. If required, slightly move arm to allow restraint gear and pawl to match. DO NOT hammer pin down, as this will damage the restraint gear teeth.
- c. Raise vehicle until the wheels slightly clear the floor, then release the START button.



- d. Check support adapters for secure contact at vehicle manufacturer recommended lift points.
- e. Continue to raise to desired height only if vehicle is secure on lift. Then release the START button.
- f. DO NOT go under vehicle if all four adapters are not in secure contact at vehicle manufacture recommended lift point.
- g. Repeat complete spotting, loading and raising procedures if required.
- h. Press down the hydraulic pressure release lever on the motor pump to lower the vehicle into the locking position. The locking latches are engaged.



**DO NOT GO UNDER VEHICLE IF LOCKING LATCHES ARE NOT ENGAGED.**



**BEFORE ATTEMPTING TO LIFT PICKUP TRUCKS OR OTHER TRUCK FRAME VEHICLES, BE SURE THAT:**

- **Vehicle frame is strong enough to support its weight and has not been weakened by modification or corrosion.**
- **Vehicle individual axle weight does not exceed one-half lift capacity.**
- **Adapters are in secure contact with frame at vehicle manufacturers recommended lift point.**
- **Vehicle is stable on lift**
- **The overhead switch bar will contact the highest point on the vehicle**

#### **4.1.4 While Using Lift**

- a. Avoid excessive rocking of vehicle while on lift.
- b. Always use safety stands as needed or when removing or installing heavy components.

#### **4.1.5 To Lower Lift**

- a. Remove all tools or other objects from lift area
- b. Press START button a few seconds to raise up a little. Then pull down the latch-release handle by left hand and at the same time press down the pressure-release lever.



**REMAIN CLEAR OF LIFT WHEN LOWERING VEHICLE. OBSERVE PINCH POINT WARNING DECALS.**

#### **4.1.6 Unloading Lift**

After the lift is lowered down onto the ground, remove adapters from under vehicle and swing arms to full drive-thru position before moving vehicle out.



**IF LIFT IS NOT OPERATING PROPERLY, DO NOT USE UNTIL ADJUSTMENT OR REPAIRS ARE MADE BY QUALIFIED LIFT SERVICE PERSONNEL.**



## 4.2 Maintenance Instructions

Contact your service provider for instruction before starting up if you are not completely familiar with automotive lift maintenance procedures. Only qualified personnel can perform maintenance on this equipment. Any failure in operation may cause personal injury or death.

### Daily

- ❖ Always keep bolts tight. Check periodically.
- ❖ Always keep lift components clean.
- ❖ Always if oil leakage is observed, contact your service provider.
- ❖ Check cables and sheaves for wear every day. Replace worn or broken parts with lift manufacturer's parts, or their equivalent.

### Monthly

- ❖ Check equalizer cable tension.
- ❖ Lubricate locking latch shafts. Push latch handle several times for oil to penetrate joints.
- ❖ Lubricate the four inside corners of the columns with heavy duty bearing grease.
- ❖ With lift lowered, check the hydraulic fluid level. If necessary add oil as described in the Installation Instruction section of this manual
- ❖ Check carriage latch synching: Latches should click at the same time. If necessary adjust equalization cables.
- ❖ Check tightness of all bolts.
- ❖ Check the nuts for tightness every week for the first month, and every month afterwards.

### Every 3 Months

- ❖ Check anchor bolts for tightness. Anchors should be torqued to 130 ft.-lbs.
- ❖ Check and clean the oil filter

### Every 6 Months

- ❖ Check fluid level of lift power unit and refill if required.
- ❖ If Lift stops short of full rise or chatters, contact your service provider.
- ❖ Replace all caution, warning or safety related decals on the lift if unable to read or missing. Reorder labels from service provider.

## 5. Exploded View / Parts List

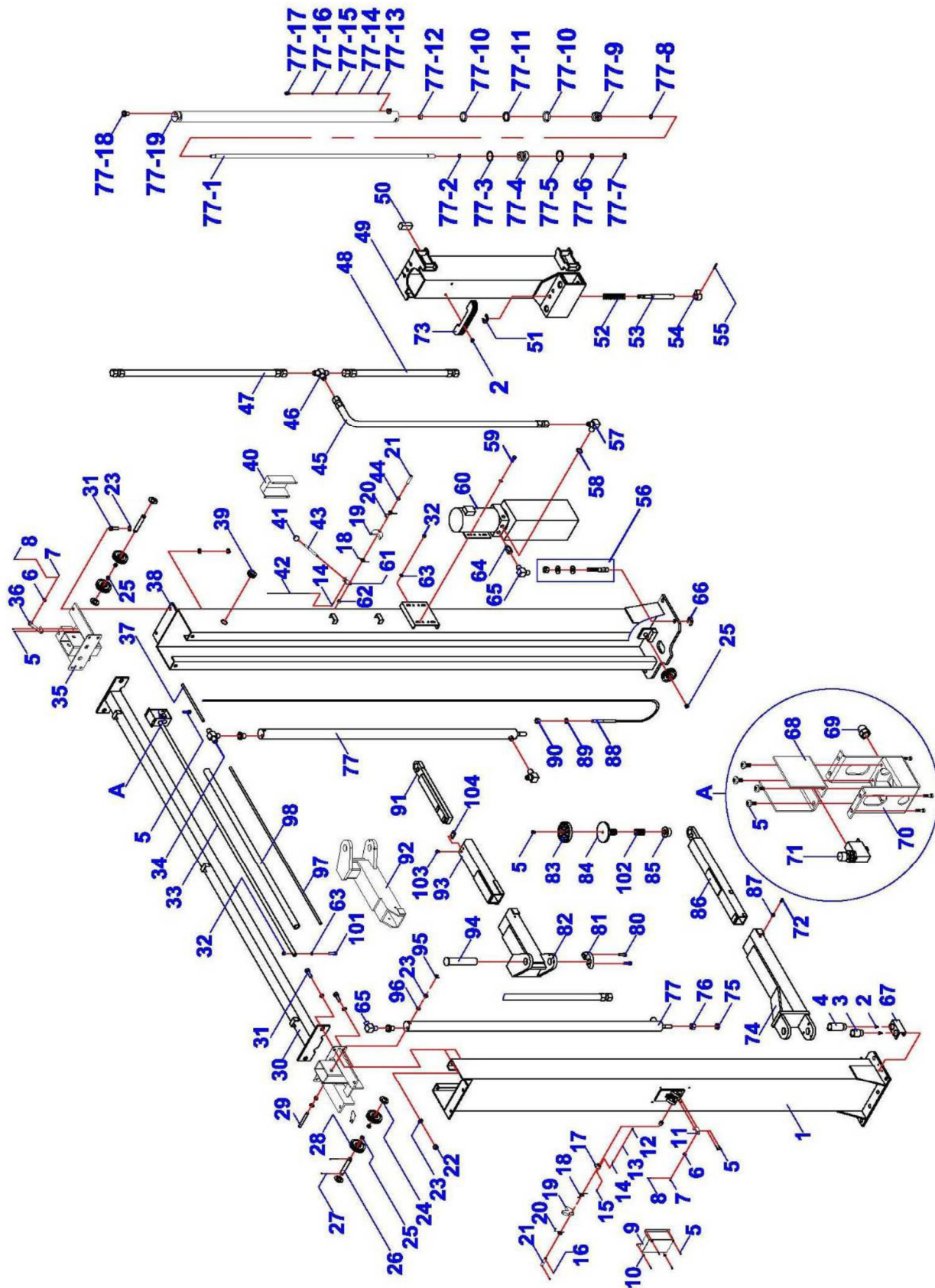

## Parts List

ITEM	CODE	DESCRIPTION	QTY
1	165948T*01-001	column (offside)	1
2	165948T*01-002	socket screw	8
3	165948T*01-003	pad adapter (low)	4
4	165948T*01-004	pad adapter (high)	4
5	165948T*01-005	screw	26
6	165948T*01-006	roller	3
7	165948T*01-007	pin 1#	3
8	165948T*01-008	split pin	3
9	165948T*01-009	cover 2#	1
10	165948T*01-010	flat washer	8
11	165948T*01-011	small frame	1
12	165948T*01-012	bolt	2
13	165948T*01-013	nut	2
14	165948T*01-014	bolt	2
15	165948T*01-015	nut	2
16	165948T*01-016	threaded pin	4
17	165948T*01-017	turning board	1
18	165948T*01-018	spring 2#	2
19	165948T*01-019	latch	2
20	165948T*01-020	spring 1#	2
21	165948T*01-021	shaft	2
22	165948T*01-022	nut	12
23	165948T*01-023	washer	28
24	165948T*01-024	flat washer	6
25	165948T*01-025	bearing	6
26	165948T*01-026	shaft	2
27	165948T*01-027	split pin	6
28	165948T*01-028	roller	6
29	165948T*01-029	shaft	2
30	165948T*01-030	cross beam	1
31	165948T*01-031	bolt	12
32	165948T*01-032	lock nut	5
33	165948T*01-033	ceiling limit bat	1
34	165948T*01-034	T-type air connector	1
35	165948T*01-035	cylinder base	2
36	165948T*01-036	large frame	2

ITEM	CODE	DESCRIPTION	QTY
37	165948T*01-037	air hose (2#)	1
38	165948T*01-038	column (main)	1
39	165948T*01-039	protect ring	1
40	165948T*01-040	cover 1#	1
41	165948T*01-041	handle ball	1
42	165948T*01-042	steel cable	2
43	165948T*01-043	handle	1
44	165948T*01-044	bearing 2#	2
45	165948T*01-045	oil hose 3#	1
46	165948T*01-046	T-type oil connector	1
47	165948T*01-047	oil hose 1#	1
48	165948T*01-048	oil hose 2#	1
49	165948T*01-049	carriage	2
50	165948T*01-050	nylon block	16
51	165948T*01-051	circlips	4
52	165948T*01-052	spring	4
53	165948T*01-053	gear shaft	4
54	165948T*01-054	small gear	4
55	165948T*01-055	cotter pin	4
56	165948T*01-056	anchor	12
57	165948T*01-057	angle connector	1
58	165948T*01-058	O-ring	1
59	165948T*01-059	bolt	4
60	165948T*01-060	motor pump	1
61	165948T*01-061	turning board	1
62	165948T*01-062	bearing 1#	2
63	165948T*01-063	washer	9
64	165948T*01-064	fitting adaptor	1
65	165948T*01-065	angle air fitting	2
66	165948T*01-066	shim	16
67	165948T*01-067	adaptor frame	2
68	165948T*01-068	switch board	1
69	165948T*01-069	cable nut	1
70	165948T*01-070	switch cover	1
71	165948T*01-071	switch	1
72	165948T*01-072	threaded pin	4

ITEM	CODE	DESCRIPTION	QTY
73	165948T*01-073	rubber bar	2
74	165948T*01-074	straight arm	2
75	165948T*01-075	thin nut	2
76	165948T*01-076	nut	2
77	165948T*01-077	cylinder	2
77-1	165948T*01-077-1	piston rod	2
77-2	165948T*01-077-2	oil seal	2
77-3	165948T*01-077-3	O-ring	2
77-4	165948T*01-077-4	guide ring	2
77-5	165948T*01-077-5	steel ring	2
77-6	165948T*01-077-6	duct ring	2
77-7	165948T*01-077-7	circlips	2
77-8	165948T*01-077-8	O-ring	2
77-9	165948T*01-077-9	piston	2
77-10	165948T*01-077-10	oil seal	4
77-11	165948T*01-077-11	guide belt ring	2
77-12	165948T*01-077-12	nut	2
77-13	165948T*01-077-13	base plate	2
77-14	165948T*01-077-14	spring	2
77-15	165948T*01-077-15	throttle valve	2
77-16	165948T*01-077-16	washer	2
77-17	165948T*01-077-17	fitting adaptor	2
77-18	165948T*01-077-18	fitting adaptor	2
77-19	165948T*01-077-19	cylinder body	2
80	165948T*01-080	bolt	8
81	165948T*01-081	large gear	4
82	165948T*01-082	curved arm left	1
83	165948T*01-083	pad rubber	4
84	165948T*01-084	lifting pad	4
85	165948T*01-085	short screw slot	4
86	165948T*01-086	straight arm extension	2
87	165948T*01-087	nut	4
88	165948T*01-088	steel cable	2
89	165948T*01-089	washer	4
90	165948T*01-090	nut	8
91	165948T*01-091	curved arm extension 2#	2

<b>ITEM</b>	<b>CODE</b>	<b>DESCRIPTION</b>	<b>QTY</b>
92	165948T*01-092	curved arm right	1
93	165948T*01-093	curved arm extension 1#	2
94	165948T*01-094	arm pin	4
95	165948T*01-095	circlips	4
96	165948T*01-096	slot	4
97	165948T*01-097	air hose (1#)	1
98	165948T*01-098	sponge bush	1
101	165948T*01-101	bolt	1
102	165948T*01-102	long screw slot	4
103	165948T*01-103	screw	4
104	165948T*01-104	fixing plate	2
105	165948T*01-105	Steel ring	4
106	165948T*01-106	Ripe grip	2
107	165948T*01-107	turnbuckle	1

## 6. Troubleshooting Guide

<b>A.</b>	<b>Problem</b>	<b>Motor does not run.</b>
	Possible cause:	Solution:
	<ol style="list-style-type: none"> <li>1. Blown fuse or circuit breaker.</li> <li>2. Incorrect voltage to motor.</li> <li>3. Bad wiring connections.</li> <li>4. Motor up switch burned out.</li> <li>5. Overhead limit switch burned out.</li> <li>6. Motor windings burned out.</li> </ol>	<ol style="list-style-type: none"> <li>1. Replace fuse or reset circuit breaker.</li> <li>2. Supply correct voltage to motor.</li> <li>3. Repair and insulate all connections.</li> <li>4. Replace switch.</li> <li>5. Replace switch.</li> <li>6. Replace motor.</li> </ol>
<b>B.</b>	<b>Problem</b>	<b>Motor runs but lift will not raise.</b>
	Possible cause:	Solution:
	<ol style="list-style-type: none"> <li>1. Open lowering valve.</li> <li>2. Pump sucking air.</li> <li>3. Suction stub off pump.</li> <li>4. Low oil level.</li> </ol>	<ol style="list-style-type: none"> <li>1. Repair or replace lowering valve.</li> <li>2. Tighten all suction line fittings.</li> <li>3. Replace suction stub.</li> <li>4. Fill tank with SAE-10, AW 32 or equivalent.</li> </ol>
<b>C</b>	<b>Problem</b>	<b>Lift will raise up only without load.</b>
	Possible cause:	Solution:
	<ol style="list-style-type: none"> <li>1. Motor running on low voltage.</li> <li>2. Debris in lowering valve.</li> <li>3. Improper relief valve adjustment.</li> <li>4. Overloading.</li> </ol>	<ol style="list-style-type: none"> <li>1. Supply correct voltage to motor.</li> <li>2. Clean lowering valve.</li> <li>3. Replace relief valve cartridge.</li> <li>4. Check or balance the vehicle weight on lift.</li> </ol>
<b>D</b>	<b>Problem</b>	<b>Lift slowly settles down.</b>
	Possible cause:	Solution:
	<ol style="list-style-type: none"> <li>1. Debris in check valve seat.</li> <li>2. Debris in lowering valve seat.</li> <li>3. External oil leaks.</li> </ol>	<ol style="list-style-type: none"> <li>1. Clean check valve.</li> <li>2. Clean lowering valve.</li> <li>3. Repair external leaks.</li> </ol>
<b>E</b>	<b>Problem</b>	<b>Slow lifting speed or oil blowing out breather cap</b>
	Possible cause:	Solution:
	<ol style="list-style-type: none"> <li>1. Air mixed with oil.</li> <li>2. Air mixed with oil suction.</li> <li>3. Oil over filled.</li> </ol>	<ol style="list-style-type: none"> <li>1. Change oil to 'non-foaming' SAE-10, AW 32 or equivalent.</li> <li>2. Tighten all suction line fittings.</li> <li>3. Only fill or add oil to tank when lift is fully lowered.</li> </ol>
<b>F</b>	<b>Problem</b>	<b>Lift going up unlevelled.</b>
	Possible cause:	Solution:
	<ol style="list-style-type: none"> <li>1. Equalizer cables out of adjustment.</li> <li>2. Lift installed on unlevelled floor.</li> </ol>	<ol style="list-style-type: none"> <li>1. Adjust the length of the cables again.</li> <li>2. Level the floor or level the column base by shims.</li> </ol>
<b>G</b>	<b>Problem</b>	<b>Anchors will not stay tight.</b>
	Possible cause:	Solution:
	<ol style="list-style-type: none"> <li>1. Holes drilled oversize.</li> <li>2. Concrete floor thickness or holding strength not sufficient.</li> </ol>	<ol style="list-style-type: none"> <li>1. Relocate lift using a new bit to drill holes.</li> <li>2. Break out old concrete and pour new pads, as required for each lift column.</li> </ol>
<b>H</b>	<b>Problem</b>	<b>Locking latches do not engage.</b>
	Possible cause:	Solution:
	<ol style="list-style-type: none"> <li>1. Latch shafts rusted.</li> <li>2. Latch spring broken.</li> <li>3. Latch cable needs adjustment.</li> </ol>	<ol style="list-style-type: none"> <li>1. Oil latch mechanism. Grease the shaft.</li> <li>2. Replace broken spring.</li> <li>3. Adjust clamps at cable end.</li> </ol>

## 7. Power Unit Priming

### IMPORTANT

#### POWER UNIT PRIMING PROCEDURE

**THE PROBLEM:** Power unit runs fine but will not pump any fluid.

**Step 1** – Locate the check valve. It's the flush plug to the left of the lowering valve.

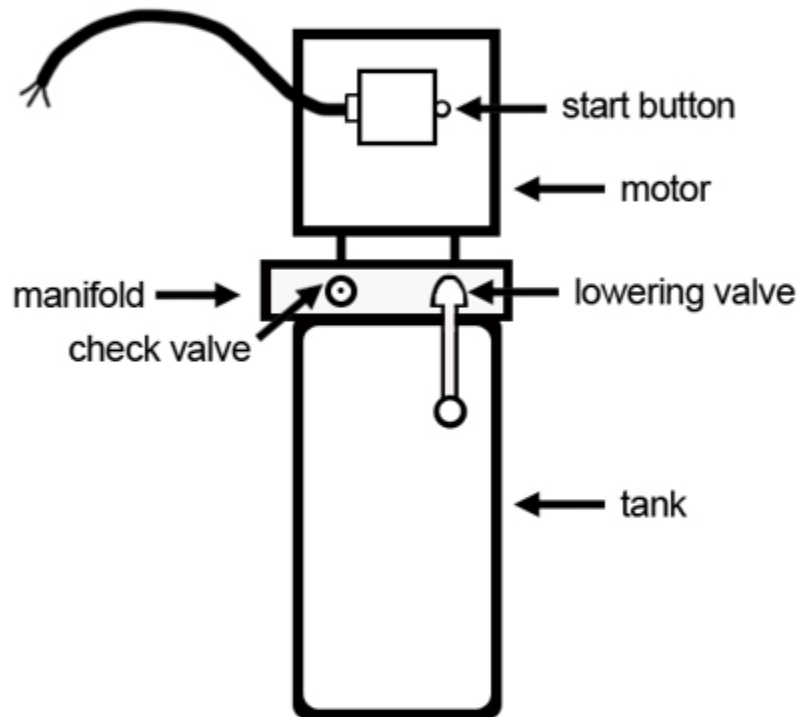

**Step 2** – Using a Hex wrench and shop towel – with shop towel in place to catch fluid – loosen the check valve plug by approximately 2-½ turns and allow fluid to bleed off.

**Step 3** – Push the START button for one second, then release for three seconds. Repeat these steps until unit starts pumping fluid.

**Step 4** – Tighten the check valve plug.

**YOUR POWER UNIT SHOULD NOW BE PRIMED**



## 8. Warranty

### LIMITED WARRANTY

#### **Structural Warranty:**

The following parts and structural components carry a five year warranty:

Columns	Arms	Uprights	Swivel Pins
Legs	Carriages	Overhead Beam	
Tracks	Cross Rails	Top Rail Beam	

#### **Limited One-Year Warranty:**

Tuxedo Distributors, LLC (Tuxedo) offers a limited one-year warranty to the original purchaser of Lifts and Wheel Service equipment in the United States and Canada. Tuxedo will replace, without charge, any part found defective in materials or workmanship under normal use, for a period of one year after purchase. The purchaser is responsible for all shipping charges. This warranty does not apply to equipment that has been improperly installed or altered or that has not been operated or maintained according to specifications.

#### **Other Limitations:**

This warranty does not cover:

1. Parts needed for normal maintenance
2. Wear parts, including but not limited to cables, slider blocks, chains, rubber pads and pulleys
3. Replacement of lift and tire changer cylinders after the first 30 days. A seal kit and installation instructions will be sent for repairs thereafter.
4. On-site labor

Upon receipt, the customer must visually inspect the equipment for any potential freight damage before signing clear on the shipping receipt. Freight damage is not considered a warranty issue and therefore must be noted for any potential recovery with the shipping company.

The customer is required to notify Tuxedo of any missing parts within 72 hours. Timely notification must be received to be covered under warranty.

Tuxedo will replace any defective part under warranty at no charge as soon as such parts become available from the manufacturer. No guarantee is given as to the immediate availability of replacement parts.

Tuxedo reserves the right to make improvements and/or design changes to its lifts without any obligation to previously sold, assembled or fabricated equipment.

There is no other express warranty on the Tuxedo lifts and this warranty is exclusive of and in lieu of all other warranties, expressed or implied, including all warranties of merchantability and fitness for a particular purpose.

To the fullest extent allowed by law, Tuxedo shall not be liable for loss of use, cost of cover, lost profits, inconvenience, lost time, commercial loss or other incidental or consequential damages.

This Limited Warranty is granted to the original purchaser only and is not transferable or assignable.

Some states do not allow exclusion or limitation of consequential damages or how long an implied warranty lasts, so the above limitations and exclusions may not apply. This warranty gives you specific legal rights and you may have other rights, which may vary from state to state.

1905 N Main St Suite C, Cleburne, TX 76033  
Ph. 817-558-9337 / Fax 817-558-9740