

12000CD

12,000 lb Capacity Two Post Symmetric Lift

**PLEASE READ ENTIRE MANUAL BEFORE
INSTALLATION OF THIS LIFT**



REV A-071213

**12,000 LB.
HEAVY-DUTY
TWO POST LIFT
WITH DIRECT DRIVE
CYLINDERS**



PRO 12000CD

Heavy-duty
Two Post Lift
with Direct Drive
Cylinders

Features:

- ◆ 12,000 lb. lifting capacity
- ◆ Direct drive high pressure cylinders
- ◆ Extra long (48") carriage for less wear on sliders
- ◆ Padded overhead cut-off bar
- ◆ Single point pneumatic lock release
- ◆ Drop in adapters are standard
- ◆ Powder-coated paint finish

SPECIFICATIONS

PRO 12000CD

Capacity	12,000 lbs.
Height overall	165"
Width overall	151 1/8"
Lifting height	5 1/2" - 72"
With adapters	79 5/8"
Width between columns	122"
Drive through	109"
Arm extension	37 1/2" - 57"
Power pack	2hp 220 vac
Shipping weight	2,235 lbs.

Structural Warranty:

The following parts and structural components carry a five year warranty:

Columns	Top Rail Beam	Uprights	Arms Swivel Pins
Legs	Carriages	Tracks Overhead Beam	Cross Rails

Limited One-Year Warranty:

Tuxedo Distributors, LLC (“Tuxedo”) offers a limited one-year warranty to the original purchaser of Tuxedo lifts and Wheel Service in the United States and Canada. Tuxedo will replace, without charge, any part found defective in materials or workmanship under normal use, for a period of one year after purchase. The purchaser is responsible for all shipping charges. This warranty does not apply to equipment that has been improperly installed or altered or that has not been operated or maintained according to specifications.

Other Limitations:

This warranty does not cover:

1. Parts needed for normal maintenance
2. Wear parts, including but not limited to cables, slider blocks, chains, rubber pads and pulleys
3. Replacement of lift and tire changer cylinders after the first 30 days. A seal kit and installation instructions will be sent for repairs thereafter.
4. On-site labor

Upon receipt, the customer must visually inspect the equipment for any potential freight damage before signing clear on the shipping receipt. Freight damage is not considered a warranty issue and therefore must be noted for any potential recovery with the shipping company.

The customer is required to notify Tuxedo of any missing parts within 72 hours. Timely notification must be received to be covered under warranty.

Tuxedo will replace any defective part under warranty at no charge as soon as such parts become available from the manufacturer. No guarantee is given as to the immediate availability of replacement parts.

Tuxedo reserves the right to make improvements and/or design changes to its lifts without any obligation to previously sold, assembled or fabricated equipment.

There is no other express warranty on the Tuxedo lifts and this warranty is exclusive of and in lieu of all other warranties, expressed or implied, including all warranties of merchantability and fitness for a particular purpose.

To the fullest extent allowed by law, Tuxedo shall not be liable for loss of use, cost of cover, lost profits, inconvenience, lost time, commercial loss or other incidental or consequential damages.

This Limited Warranty is granted to the original purchaser only and is not transferable or assignable.

Some states do not allow exclusion or limitation of consequential damages or how long an implied warranty lasts, so the above limitations and exclusions may not apply. This warranty gives you specific legal rights and you may have other rights, which may vary from state to state.

Model Number	12000CD
Capacity	12,000 lbs.
Lifting height with adapters	5.5" - 72" 79.625"
Height overall	165"
Width between columns	122"
Drive through	109"
Width overall	151.125"
Arm extension	37.5" - 57"
Power pack	2hp 220vac
Shipping weight	2235 lbs.

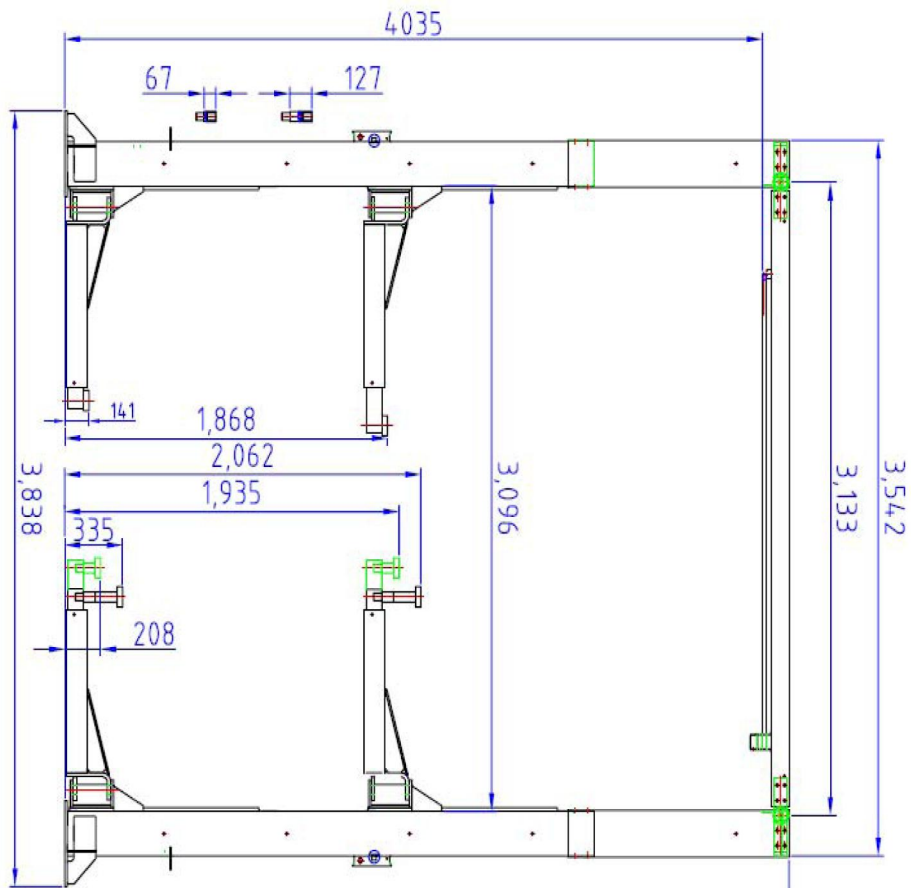

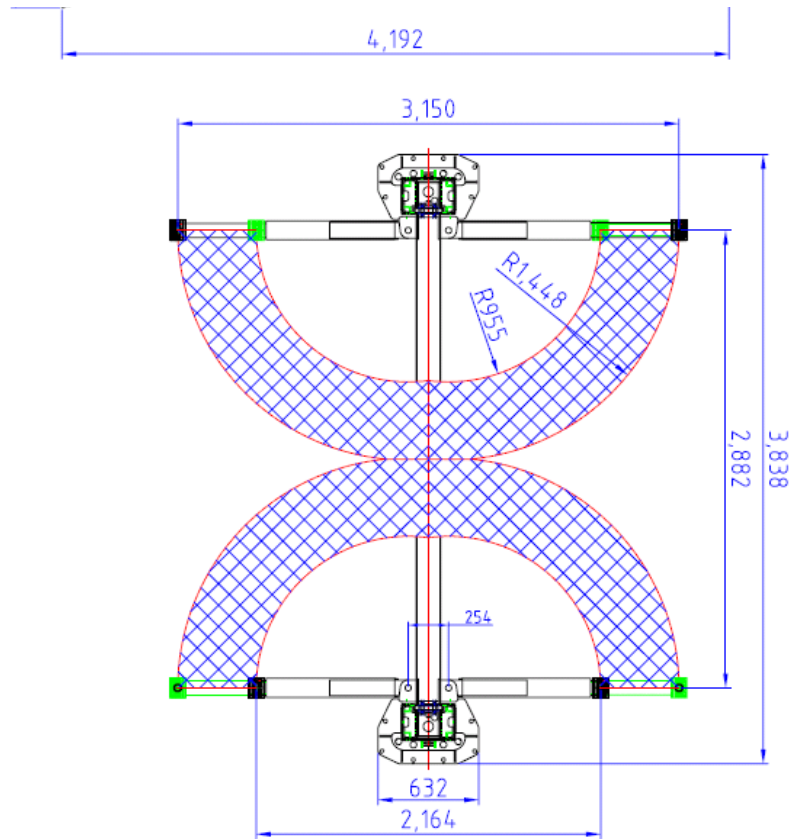

INSTALLATION INSTRUCTIONS

Choosing A Location

- **Use architects' plans when available.** See Floor Layout on Page 6 for typical layout of the 12000# inverted cylinder model.
- **Two Post Lifts** require a *minimum* ceiling height of 3" higher than the overall height of the lift being installed. For the TP12KC-D this will be 168" (14').
- **The Steel Reinforced Concrete** floor must be level, have a *minimum* thickness of 4 inches, and retain a *commercial* rating of 3500 psi. The concrete **must** be cured for a **minimum of 28 days**.
- **Before making a Final Decision**, consider the amount of workday traffic flowing in and around the location you have chosen. Also consider the amount of room out front of the lift for a workbench or diagnostic equipment. There may also be some future building plans to consider. Are you satisfied with your selection?

Important General Information

1. There are numerous blends and mixes and additives these days for concrete. All of these work well when used in the proper application. However, years of experience have shown that nothing beats a properly cured, steel reinforced concrete slab for this application. Another thing to watch is additives that claim to harden the concrete faster or reduce the cure time. Again, these things have their place, but not in this application! ***A steel rod or mesh reinforced slab cured 28-30 days with the slab kept properly hydrated gives the best results.***
2. Checking bolts for tightness to some people means that once a week they grab a wrench and go around yanking a quarter of a turn on every nut and bolt they see. This is, of course, not the proper way of handling any bolt, ***especially*** the stress anchor used to anchor your lift. ***When the anchors are installed, they must be torqued with a torque wrench to 150 foot-pounds initially.*** After a period of time, they will loosen up some. This is normal. When checking the anchors just put a wrench on them and “feel of them” or apply a small amount of torque to the bolt. If it is tight, it is good to go. If it is loose, get a torque wrench and tighten it to 60-90 foot-pounds.
3. The lift is not designed for an outdoor installation because of the possible damage and degradation to the hydraulics and the electrical components caused by direct exposure to the elements. If the unit is installed in a building or outbuilding with a floor that is anything other than the recommended concrete floor, a pad can be poured. The size and construction of the pad can vary depending on the soil conditions and the local weather conditions. It is recommended that each of these situations be handled separately by a local engineer.
4. Never place a lift in a pit or depression in a garage area or any environment where gasoline is around. Gasoline fumes tend to gather at the floor and low areas, so the lift must be mounted on the main floor of the building and not in the basement or a pit.
5. Always remember that your lift is rated at 12000 pounds. This means that the lift will safely and reliably lift a load of 12000 pounds as long as that load is evenly distributed on all four arms. If the load is offset or unevenly distributed, then one post can actually be operating at a load greater than 12000# and the lift can be overloaded with less than the rated load. So the lift load rating is ***12000 pounds or 3000 pounds per arm.***

Positioning the Post (Columns)

Carefully examine the packed unit for damage before unpacking. Any claims for damage should be filed with the freight carrier at delivery. Unbolt the package being careful to save the bolts and use them to reinstall the top caps after unpacking the lift. Place posts in bay using dimensions shown in Floor Layout (Figure 1). The bases must be square with the layout lines as shown. It is recommended that the extensions be mounted to the posts before standing them up. You will need a considerable amount of help standing up these posts.

Drilling and Anchoring

A. Drill 3/4" x 5-1/2" (minimum depth) holes in the *concrete* floor using the holes in the base plates as guides. Drill the holes perpendicular to the surface, being sure not to enlarge them by allowing the drill to wobble. Do not ream-out the holes. (See Anchoring Instructions, Figure 2). ***Be careful when drilling the holes, the posts can tip over.***

B. Blow all of the dust and debris from the holes, then clean around the openings with a wire brush. A clean hole will improve the prospect of solid anchoring.

c. It is recommended that the lift to be located 10' – 12' from the nearest obstruction in front of the lift and 2' – 3' from the nearest obstruction on the sides of the lift.

2. To install Anchor:

- A. Assemble the washer and nut onto the anchor bolt with nut just below impact section of bolt.
- B. With a hammer, ***carefully*** tap the anchor bolt into the concrete until the washer is resting on the base of the column. **DO NOT DAMAGE THE NUT OR THREADS!**
- C. Before tightening the nuts, level and plumb the columns, using the shims provided.
Note: If more than 1/2" of shims is required to level the post, **Do Not Use the Anchors supplied with this lift. It will be necessary to purchase longer anchors for your application. The brand of anchor recommended is the Hilti Kwik-Bolt.**
- D. When columns are level and plumb, tighten the nuts with a *Torque Wrench* to 150 ft-lb. If anchors do not tighten to 150 ft-lbs in existing floor, replace concrete under each post with a 6' x 6' x 10" thick pad keyed into and flush with the existing floor. Concrete must be 3500 PSI minimum.

NOTE: NEVER USE AN IMPACT WRENCH TO TIGHTEN ANCHOR BOLTS!

Attaching The Overhead Beam and Shut-Off Bar

1. The overhead beam is attached to the extensions at the ends with eight nuts and bolts. See picture.



2. The cable sheaves must be assembled onto the shafts with the spacers supplied as shown in the picture prior to attaching the overhead channel.

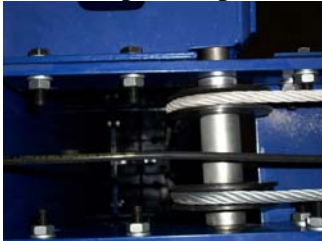

3.To Install the Shut-Off Bar

Attach the shutoff bar and switch housing to the underside of the overhead beam. Attach single bolt and bar first, then install switch housing.

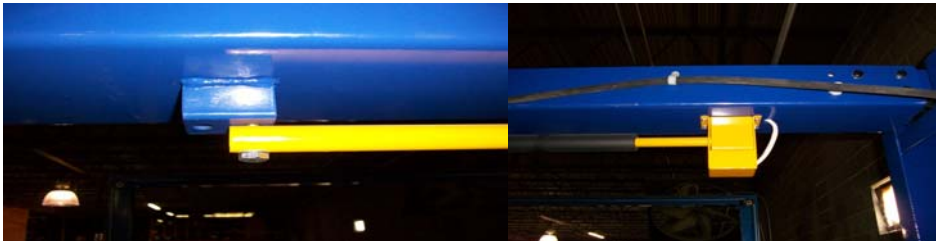

4. Run electrical cord into the beam and back out of the column using provided bulk head fittings.



Attaching the Air Actuator

1. Locate offside air cylinder and insert 6mm hose into PTC fitting.



2. Run air hose up and over top of column, running through top side of overhead beam and down to main side lock assembly.

3. Connect air hose to provided PTC 3-way fitting, cut to size a piece of air hose and run to main side air cylinder PTC fitting. Remaining hose will be connected from 3-way fitting to palm actuated air release button valve.



4. Attach palm valve to steel bracket on side of column.



5. Connect shop air to palm valve. We recommend using leftover hose and NPT fitting (not included).

Installing the Equalizer Cables

A. Manually lift both carriages to about waist height. Be sure they are the same height and on the same latch location on the carriage.

B. Install the Equalizer Cables using the Routing for the lift as shown in the picture. The cables should be taught, but no too tight. Be certain to tighten the jam nuts.

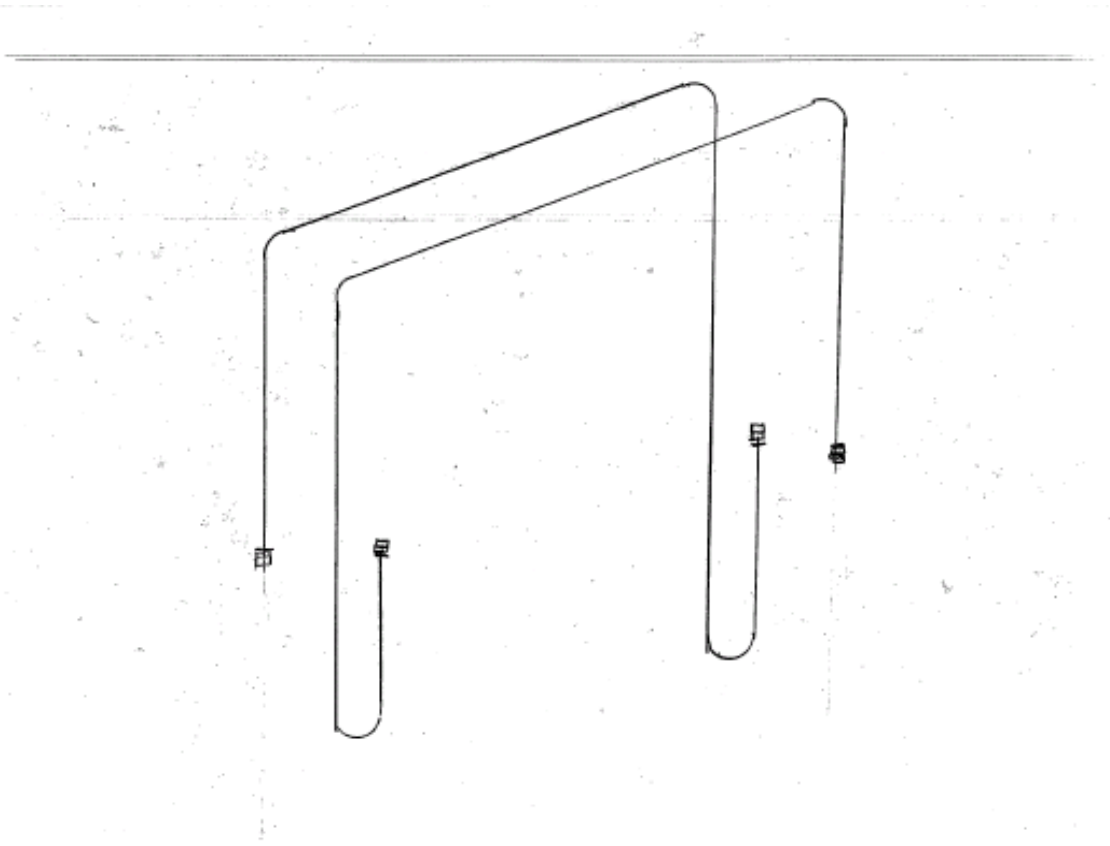

Cables are routed identically the same on both columns. Cable on right is routed down and around the sheave then up and over the overhead beam. Then routed down to the top of the carriage.



Be sure cables are seated securely on the sheaves.

Power Unit Placement and Connection of the Hydraulic Hoses

1. Remove the power unit from the box and locate the mounting hardware. For easy mounting, place two bolts through the middle slots on the power unit mounting plate and start the nuts on them. Then lift the unit up and slide the unit into position while guiding the bolts into the slots on the bracket from the top. Install the other two bolts and tighten securely.
2. Install longest hose first. One end has 90 degree fitting that hooks to bottom of the offside cylinder and then route hose through the leg gusset.
DO NOT OVER TIGHTEN FITTINGS!!



3. Route the hose up the column installing the hose clamps as you go. Then follow across the outside of the overhead beam (installing hose clamps as you go). Down the main side column towards your power unit.
4. Run hose through the top of your power unit bracket until the end of your hose comes through the bottom of the bracket.
5. Install power unit elbow fitting into the port that has the red plastic cap located on the left side of your power unit. Connect shortest hydraulic hose to the elbow fitting. Connect the T fitting to the shortest hose and then connect overhead hose to the T fitting.
6. Connect medium length hose with 90 degree fitting to main side cylinder and thread through leg gussets. Run the hose up to the T fitting and tighten. See pictures –



NOTE: DO NOT OVER-TIGHTEN THE HYDRAULIC HOSE CONNECTIONS!

Attaching the Swing Arms and Arm Restraints

1. Locate the arms, arm pivot pins, and hardware. Place the arm clevis end into the clevis on the carriage. Place thrust washer on bottom side of carriage clevis.
2. Slide the pivot pins through the arms and carriage until it bottoms out.
3. Check the operation of the arm restraints. Make sure they engage and disengage properly.

Electrical Connection

NOTE: WE STRONGLY RECOMMEND THAT YOU USE A LICENSED, PROFESSIONAL ELECTRICIAN TO INSTALL THE POWER TO YOUR TWO POST LIFT!

Filling the Hydraulic Fluid Tank

Remove the vent-cap from the top of the Hydraulic Fluid Tank attached to the Power Unit. Using a funnel, carefully pour in the Hydraulic Fluid (approximately 12 quarts) until fluid gets near the top of the tank. Replace the vent-cap.

We Recommend Using One of the Following Fluids:

Dextron III Non-Detergent

AW #32 Hydraulic Oil

Bleeding the System

1. Actuate the power unit and hold the button until both carriages lift off the locks.
2. Carefully loosen the bleeding screw at top end of the cylinder and allow the trapped air to escape. **CAUTION! *The air in the cylinders is under pressure. Protect your eyes and cover the end of the cylinder with a rag because oil may spray out of the cylinder.***
3. Repeat the process for the other cylinder.

CAUTION: DO NOT OVER TIGHTEN THE BLEED PLUG

Adjusting the Equalizer Cables to Synchronize Carriages

Raise and lower the lift several times while listening to the *clicking* of the safety locks in each column. If the safety locks are not clicking in unison (at the same time), determine which carriage is running behind, and tighten (just a few turns) the adjustment bolt on the *opposite* side. When the cables are properly adjusted, they should feel fairly tight.

Final Assembly

1. Using the adhesive cable anchors and cable ties, fasten the overhead switch cord and the air lines to the posts.
2. Install lock release covers over both assemblies with provided screws.
3. **Check all nuts and bolts**, making sure they are tight. Check the jam nuts on the equalizer cables for tightness.
4. **Check all of the hydraulic fittings** for possible leaks. Check **all** the fittings for proper tightness.
5. **Make sure the Carriages are synchronized.**
6. **Make sure post are greased.**
7. **Place a vehicle on the lift** (see operating section for instructions below for to the safe and proper way to lift a vehicle), raising the vehicle until it clears the floor. Lower the lift all the way to the floor and recheck all the anchor bolts. Raise the vehicle all the way to the top and lower all the way to the floor several times. This procedure will ready the lift for continued operation.

OPERATION

1. Center the vehicle left and right between the posts.

2. Position the swivel pads under the frame of the car at the *proper lifting points*. (To find the proper lifting points, consult the vehicle's service manual or other approved publication.)
3. Push the up button and raise the lift until the swivel pads make contact with lifting points.
4. Check all swivel pads to make certain all adapters are making *full and proper contact*. **NEVER** go under a vehicle unless all adapters are in secure contact with the vehicle.
5. Raise the vehicle approximately 2 feet and check the stability by rocking the vehicle. *Make sure vehicle weight is centered*. Do not raise if weight is front or tail heavy.
6. Raise the vehicle to the desired height and lower on the carriage latches. **NEVER** go under a vehicle unless the carriage latches are engaged. If any heavy parts are to be removed, use a set of high stands for added safety.
7. Before lowering, check the area under the vehicle to be sure it is clear. Raise lift slightly, pull the Latch Release Handle and hold, then pull down on the lowering release arm and lower **SLOWLY**. *Keep feet clear*.
8. After lowering, rotate the swing arms back out of the way.

MAINTENANCE SCHEDULE

DAILY

1. Always keep bolts tight.
2. Check for oil leaks.

MONTHLY:

1. Re-torque the anchor bolts if necessary. (See CAUTION! below)
2. Lubricate chains/cables with spray lubricant.
3. Check all connectors, bolts and pins to insure proper mounting.
4. Make a visual inspection of all hydraulic hoses and lines for possible wear or interference.

!

ALL ANCHOR BOLTS SHOULD ALWAYS BE TIGHT. Check the bolts periodically and tighten if necessary to 60-90 ft.-lbs. after the bolts have been set at installation. If any of the bolts do not function for any reason, the lift should be shut down until the bolt has been replaced.

EVERY SIX (6) MONTHS:

1. Make a visual inspection of all moving parts for possible wear, interference or damage.
2. Check all pulleys for proper lubrication. If pulleys seem to be dragging during lifting or lowering, lightly oil the axle.
3. Check and adjust as necessary, equalize tension to insure level lifting.
4. Check columns for plumbness.
5. Check fluid level of power unit.
6. Lube columns.

TROUBLESHOOTING THE LIFT

1. Motor does not run:
 - A. Breaker or fuse blown.
 - B. Motor thermal overload tripped.
 - C. Defective UP switch. Replace.
 - D. Faulty wiring connections. Call electrician.
 - E. Check the overhead shut-off bar operation.
It could be faulty or stuck-thus holding the switch open.
2. Motor runs but lift will not raise:
 - A. Trash is under check valve. Push handle down and push the UP button at the same time. Hold for 15 seconds. This should flush the system.
 - B. Remove the check valve cover with an Allen wrench. Clean the ball and seat and replace the cover.
 - C. Oil level low. Oil level should be just under the vent cap port when the lift is down.
3. Motor runs but lift picks up partial load only:
 - A. Faulty relief valve. Replace.
 - B. Oil is coming out of breather on cylinder.
 - C. Seals damaged.
4. Oil blows out of breather:
 - A. Oil reservoir overfilled.
 - B. Lift lowered too quickly while under a heavy load.
5. Motor hums and will not run:
 - A. Impeller fan cover is dented in. Take straighten.
 - B. Faulty wiring - Call an Electrician.
 - C. Bad capacitor - Call an Electrician.
 - D. Low voltage - Call an Electrician.
 - E. Lift over loaded.
6. Lift jerks up and down:
 - A. Cables are too loose - (See Adjusting The Equalizer Cables).
 - B. Air in system - bleed the system.
(See Installation Instructions - Bleeding the System)

ITEM	DESCRIPTION	QTY
1	Column jointings	1
2	Adjust washer	12
3	Upset bolt	12
4	Spindle	4
5	Spindle	4
6	Baffle ring	6
7	Pin	2
8	Spring	2
9	Safety ass'y	2
10	Cam	2
11	Pin	2
13	Elbow fitting joint	2
14	Pin	4
15	Pin	2
16	Fitting joint	2
17	Cylinder	2
18	Cross beam parts	1
19	Bolt	5
20	Washer	9
21	Pole	1
22	Nut	5
23	Sponge bush	1
24	Rubber block	16
25	Carriage	2
26	Hydraulic cylinder	2
26-1	Cylinder barrel	2
*26-2	Dust ring	2
26-3	Guide ring	2
26-4	Fixed part for piston	2
*26-5	O-ring	4
26-6	Piston rod	2
26-7	Limit ring	2
*26-8	Guide ring	2
*26-9	O-ring	2
*26-10	Packing ring	2
63	Pin	4
64	Gear	4
65	Pin	8
66	Gear	4
67	Rack spindle	4
68	Spring	4
69	Key ring	4
70	Fitting joint	2
71	Nut	8
72	Washer	4
73	Steel cable	2
*74	O-Ring	1

75	T fitting joint	1
76	Fitting joint	1
77	Plug	1
28	Flat washer	104
29	Nut	48
30	Link plank	4
31	Cap	2
32	Bush	4
33	Bush	2
34	Wheel	6
35	Spindle	2
36	Vice column jointings	2
37	Hoop	16
38	Screw	16
39	Screw	16
40	Plate	1
41	Switch cover	1
42	Switch	1
43	Cable	1
44	Oil hose	1
45	Oil hose	1
46	T fitting joint	1
47	Oil hose	1
48	Flat washer	8
49	Cover	2
50	Elbow fitting joint	2
51	Switch	1
52	Power unit	1
53	Column jointings	1
54	Air hose	1
55	Air hose	1
56	Air hose	1
57	T fitting joint	1
58	Screw	12
59	Rubber washer	4
60	Salver jointing	4
61	Flex arm	4
63	Pin	4
64	Gear	4
65	Pin	8
66	Gear	4
67	Rack spindle	4
68	Spring	4
69	Key ring	4
70	Fitting joint	2
71	Nut	8
72	Washer	4
73	Steel cable	2
*74	O-Ring	1

75	T fitting joint	1
76	Fitting joint	1
77	Plug	1
64	Gear	4
65	Pin	8
66	Gear	4
67	Rack spindle	4
68	Spring	4
69	Key ring	4
70	Fitting joint	2
71	Nut	8
72	Washer	4
73	Steel cable	2
*74	O-Ring	1
75	T fitting joint	1
76	Fitting joint	1
78	Washer	4

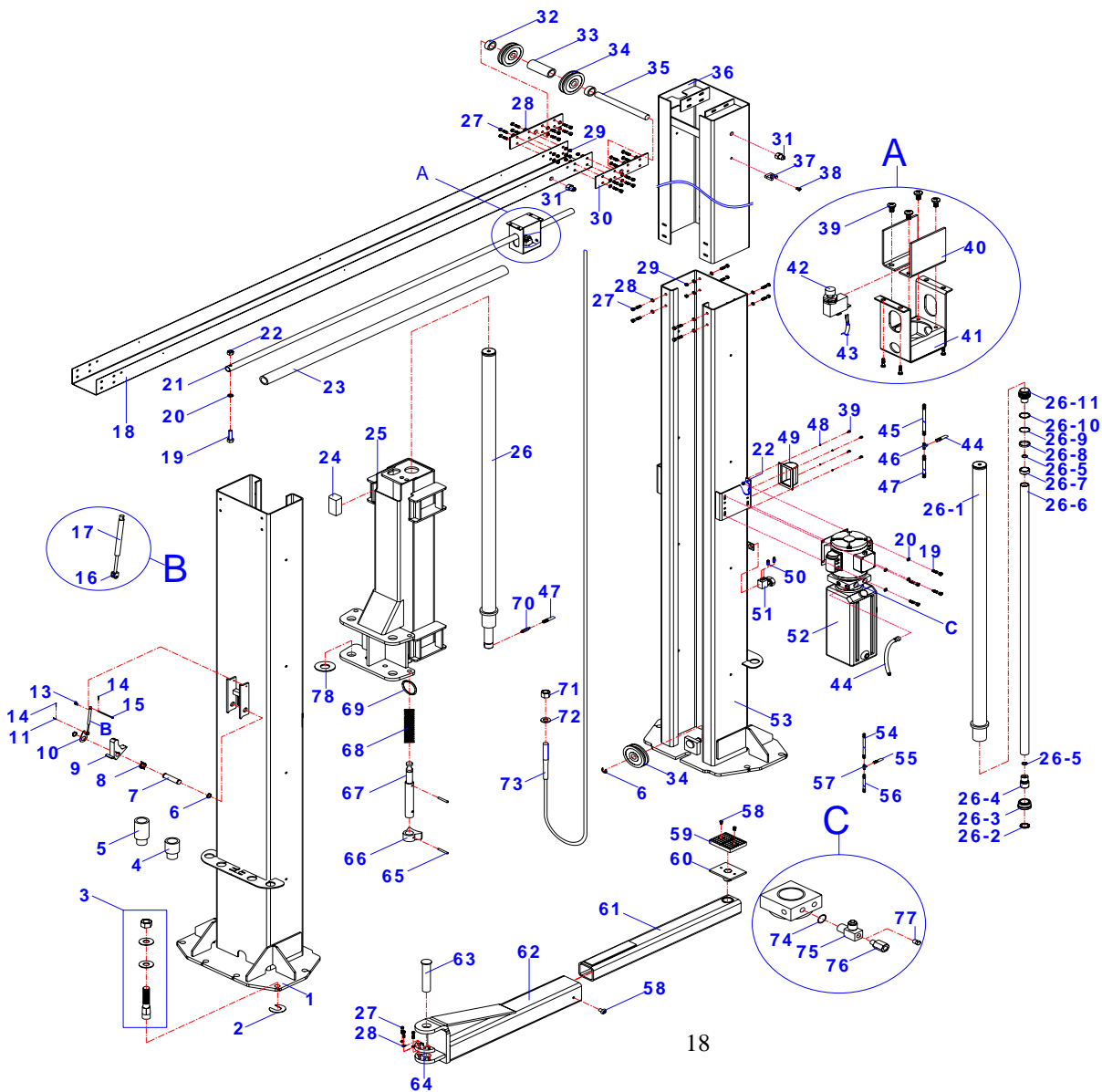

IMPORTANT

POWER UNIT PRIMING PROCEDURE

THE PROBLEM: Power unit runs fine but will not pump any fluid.

Step 1 – Locate the check valve, the flush plug to the left of the lowering valve.
(See drawing below.)

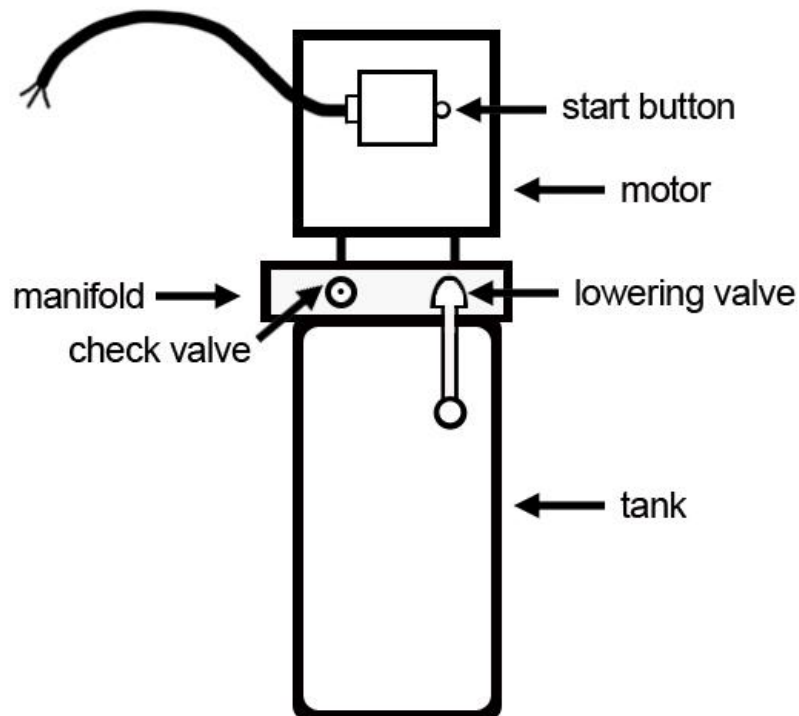

Step 2 – Using an Allen wrench and shop towel – with shop towel in place to catch fluid – loosen the check valve plug 2 ½ turns to allow it to leak.

Step 3 – Push the START button for one second, then release for three seconds.
Repeat these steps until unit starts pumping fluid.

Step 4 – Tighten the check valve plug.

YOUR POWER UNIT SHOULD BE PRIMED