

Mining Wheel Stud Press

50101

**TIGER
TOOL**

Have What It Takes

Safety Warning

Read all instructions and safety warnings prior to operation. Failure to do so could result in equipment damage, personal injury or even death.

CAUTION: USE REPLACEMENT PARTS AND ACCESSORIES PROVIDED BY TIGER TOOL ONLY. ALL REPLACEMENT PARTS AND ACCESSORIES ARE AVAILABLE. KEEP HYDRAULIC COUPLER PROTECTED WHEN NOT IN USE. DUST CAPS SHOULD BE USED ON COUPLERS WHEN NOT IN USE TO AVOID CONTAMINANTS FROM ENTERING THE HYDRAULIC CYLINDER AND POWER SOURCE. THIS PRACTICE WILL HELP TO EXTEND THE LIFE OF THIS PRODUCT AND ENSURE CONTINUED CONSISTENT OPERATION.

- **Stay Alert!** Watch what you are doing and use common sense when operating this tool.
- Inspect product for damage prior to using; do not use if product is in unsafe condition.
- Do not operate tool while under the influence of drugs, alcohol or medication.
- Always use safety equipment to prevent injuries. Approved face and eye protection must always be worn by the operator, as well as others in the work area.
- Do not overreach. Keep proper footing and balance at all times.
- Dress properly. Do not wear loose clothing or jewelry. Keep your hair, clothing and gloves away from moving parts.
- Keep hands clear of all pressurized hydraulic components.
- Always ensure hoses are free from sharp bends and kinks.
- Keep your work area clean and well lit.
- Cylinders are designed for 10,000 psi (700 bar) maximum working pressure. Do not connect to a pump with a higher rated pressure. Use a pressure gauge in the system at all times. Ensure all components in the system are rated for 10,000 psi (700 bar).



View demonstration videos and a complete product list at tigertool.com

Technical Support
1.800.661.4661

Mining Wheel Stud Press

50101

**TIGER
TOOL**

Have What It Takes

Operating Instructions

Tool Setup

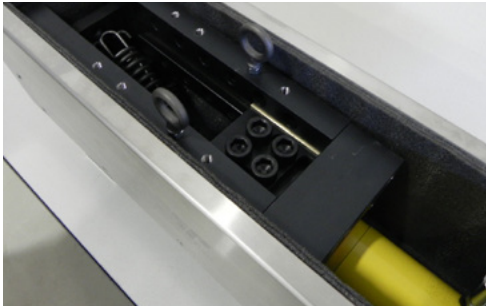

- 1 Remove the two small eyebolts from the case and attach to the frame.

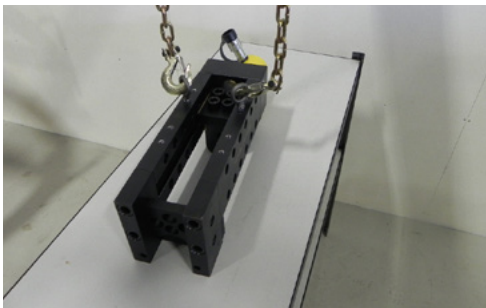

- 2 Attach the overhead crane to the eyebolts and carefully remove the tool from the box and place on a solid flat surface.

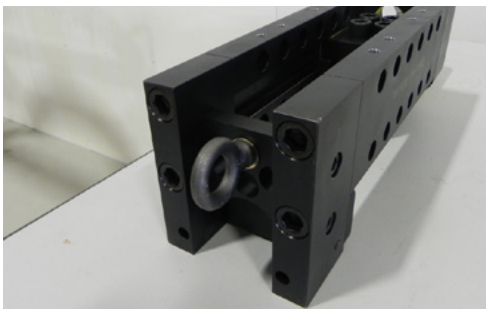

- 3 Remove the two small eyebolts and return them to the case. Attach the large eye bolt to the end of the tool.



- 4 Attach the spring assembly to the eye bolt and the O/H crane.

Lift and flip the tool over on its back to install the appropriate anvils and adapters.

Attach the hydraulic power supply to the cylinder. (Use any 10,000 psi air/hydraulic or manual hydraulic pump.)



View demonstration videos and a complete product list at tigertool.com

Technical Support
1.800.661.4661

Mining Wheel Stud Press

50101

**TIGER
TOOL**

Have What It Takes

Stud Removal

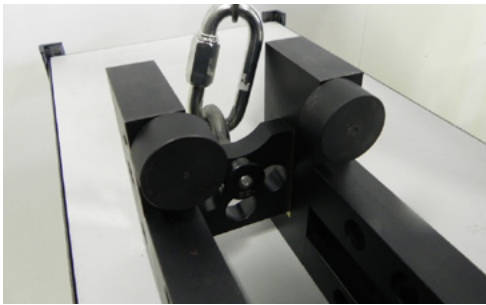
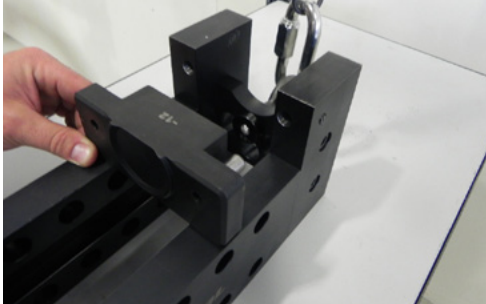

- 1 For removal of the first stud, use the two round anvils (-19). Remove the install anvil (-12) and replace with the two round anvils (-19).

- 2 Attach the appropriate stud pusher adapter to the cylinder end. (Small-11 or large-16, depending on the stud size).

Continued on next page.



View demonstration videos and a complete product list at tigertool.com

Technical Support
1.800.661.4661

Mining Wheel Stud Press

50101

**TIGER
TOOL**

Have What It Takes

Stud Removal - continued.



A

- 3 Maneuver the tool into position, straddling the stud for removal, with the round anvils on the heads of the studs to each side. **(Figure A)**

The adapter on the cylinder side should be aligned with the threaded end of the stud. **(Figure B)**

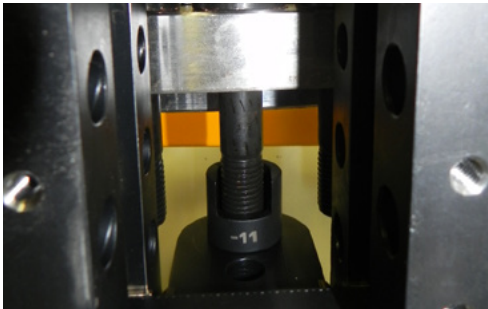

B

- 4 Pressurize the hydraulic cylinder and press the stud out of the wheel hub.
- 5 For the rest of the studs, one side of the tool anvil will need to be replaced with anvil -14 or -15, depending on the direction you intend to rotate while removing the studs. The round flat anvil (-19) should be used where there is no longer a stud and the stepped anvil (-14 or -15) should be used on the side, where there is a stud.

To remove the final stud you will need to use the two round anvils (-19) again.



View demonstration videos and a complete product list at tigertool.com

Technical Support
1.800.661.4661

Mining Wheel Stud Press

50101

**TIGER
TOOL**

Have What It Takes

Stud Installation

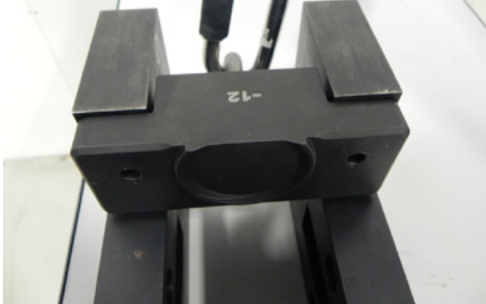

- 1 Attach the one-piece install anvil (-12).

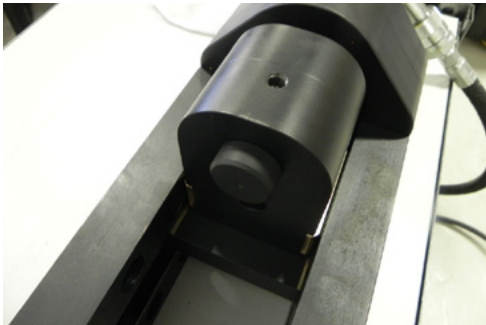

- 2 Attach the small button adapter (-18) to the cylinder end.

Select the appropriate install tube (-17 or -21, depending on the size of the stud) but do not attach.



Continued on next page.



View demonstration videos and a complete product list at [tigertool.com](https://www.tigertool.com)

Technical Support
1.800.661.4661

Mining Wheel Stud Press

50101

**TIGER
TOOL**

Have What It Takes

Stud Installation - continued.

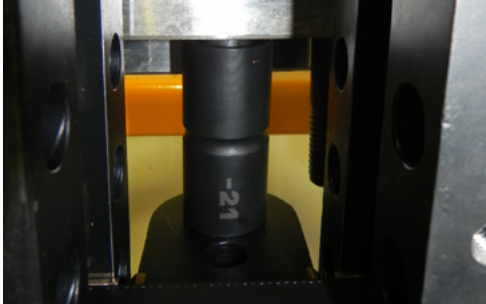

- 3 Maneuver the tool in to position with the install anvil centered on the head of the stud.

Slide the install tube over the stud and seat the other end over the button adapter.

- 4 Pressurize the hydraulic cylinder until the stud is fully seated in place.

Here at Tiger Tool, your satisfaction is our number one priority. Should you have any questions about this or any of our products, please call us at 1.800.661.4661.



View demonstration videos and a complete product list at [tigertool.com](https://www.tigertool.com)

Technical Support
1.800.661.4661

Mining Wheel Stud Press

50101



Have What It Takes

Attachments

All part numbers: 50101-

MINING WHEEL STUD PRESS ATTACHMENTS (ALL PART NUMBERS: 50101-)

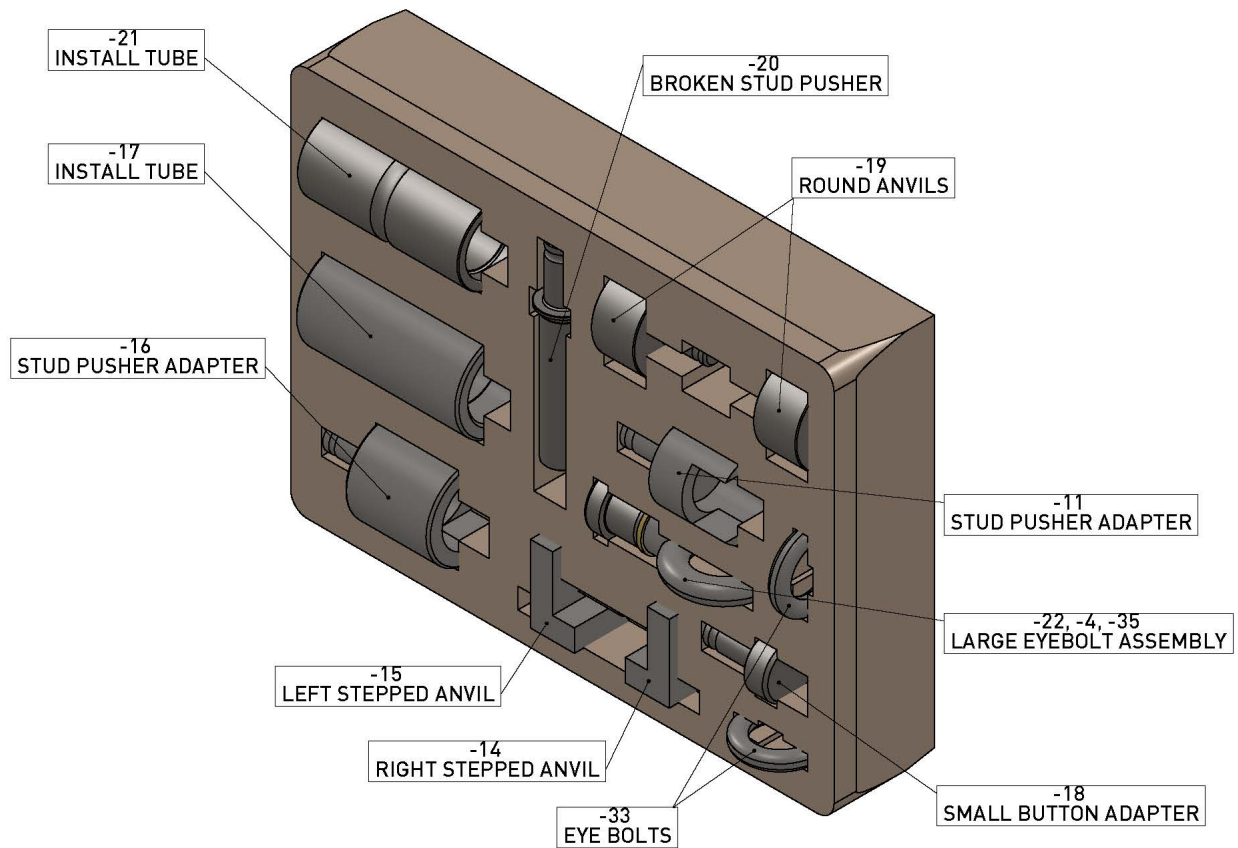

View demonstration videos and a complete product list at tigertool.com

Technical Support
1.800.661.4661

Mining Wheel Stud Press

50101

**TIGER
TOOL**

Have What It Takes

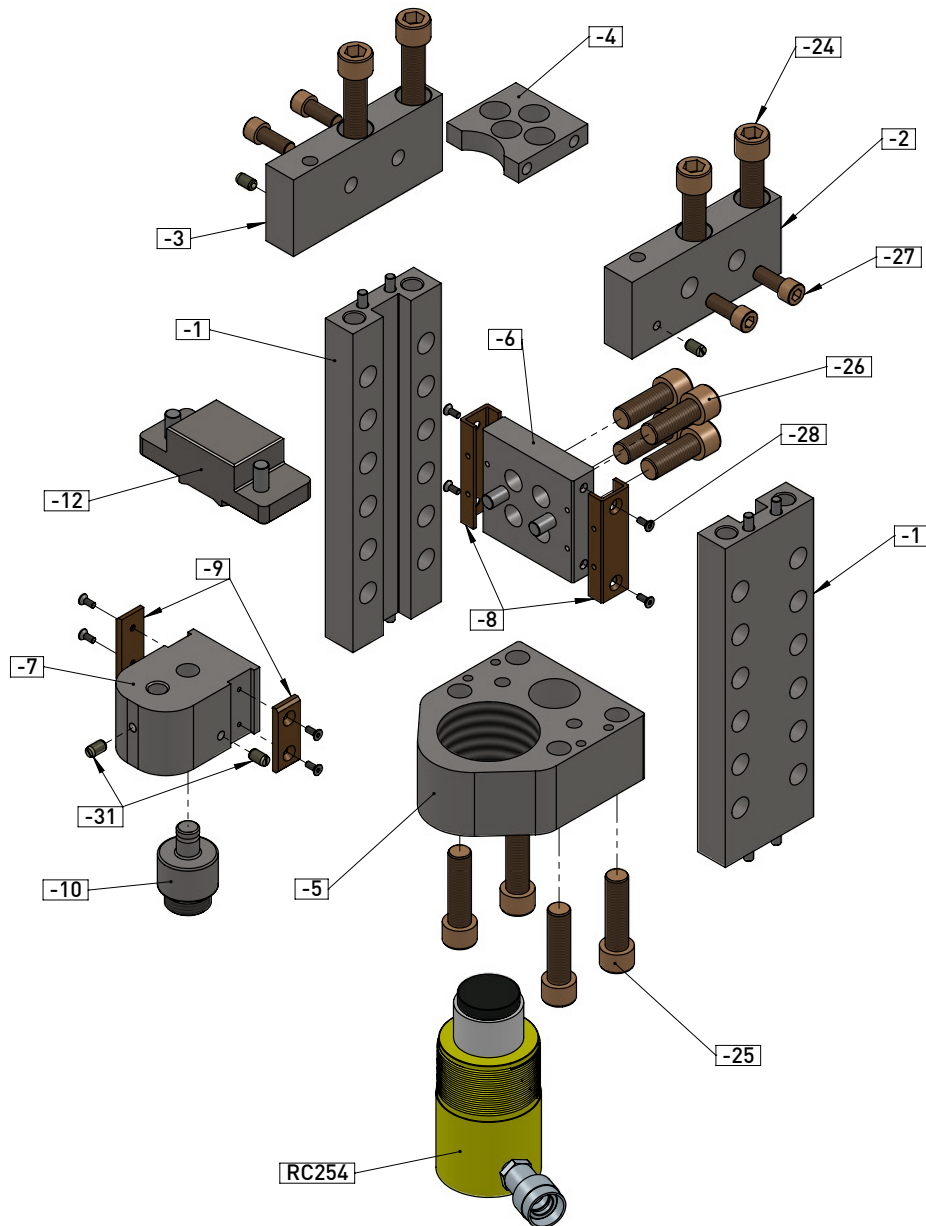

View demonstration videos and a complete product list at tigertool.com

Technical Support
1.800.661.4661