

20201 (KIT 200) HEAVY DUTY MECHANICS KIT

U-JOINT PULLER (PART # 10102)

Eliminates damage to driveshaft, yokes, cups and bearings.

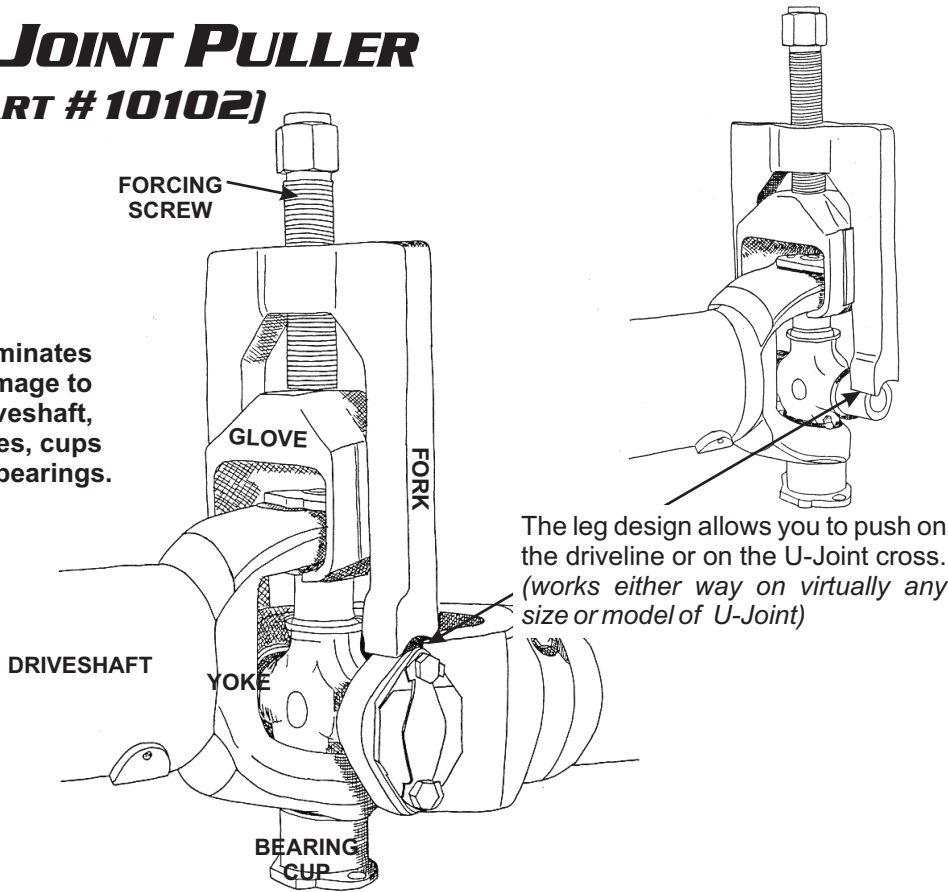

OPERATING INSTRUCTIONS

- 1) Remove all fasteners from bearing cups.
- 2) Slip the U-Joint Puller over the yoke of the driveline.
- 3) Turn the tool's forcing screw clockwise with either a hand or impact wrench. (Note: reverse thread)
- 4) Once bearing cup has been removed, repeat the process on the remaining bearing cups.

The 10102 U-Joint Puller may be used with up to a 1-inch impact wrench without voiding warranty.

Stay Alert! Watch what you are doing and use common sense when operating this tool. Do not operate tool while under the influence of drugs, alcohol, or medication. Always use safety equipment to prevent injuries. Approved face and eye protection must always be worn by the operator, as well as others in the work area. Keep your work area clean and well lit.

BEARING CUP INSTALLER (PART # 10201)

OPERATING INSTRUCTIONS

- 1) Ensure all parts to be assembled are clean and/or greased where applicable.
- 2) Double check all needle bearings are present and placed correctly.
- 3) Start pressing bearing cup into yoke by hand, making sure u-joint cross and bearing cup bolt holes line up.
- 4) Place installer onto bearing cup, threading bolts into yoke.
- 5) Using an impact or hand wrench, turn forcing screw until cup is flush to yoke.
- 6) Remove tool, and install bearing cup bolts.

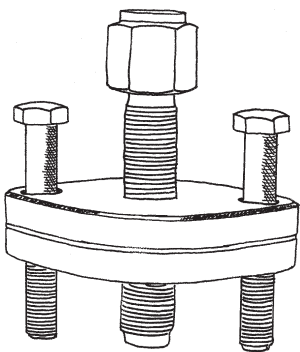

TIE ROD END REMOVER (PART # 10301)

OPERATING INSTRUCTIONS

- 1) Remove any original nuts and/or cotter pins from parts to be separated.
- 2) Select correct tool according to thread size of tie rod.
- 3) Spin the tool completely onto the threaded arm.
- 4) Back tool off one complete turn backwards.
- 5) Strike the remover with a hammer; tie rod will become loose.
- 6) Remove tool and part to be removed will drop off.

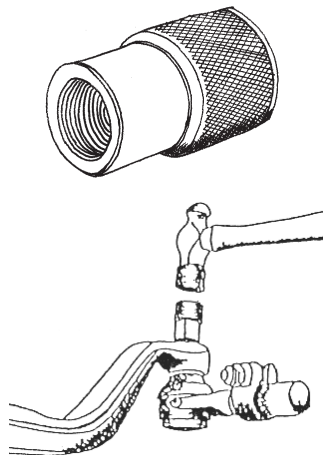

Lubrication: Use any quality oil on threads (not anti-seize) and any quality grease on load bearing surface in glove, under black plastic cap. For more information, please call us at 1-800-661-4661.

TIGER TOOL International Incorporated®

Phone: 1-800-661-4661

20201 (KIT 200) HEAVY DUTY MECHANICS KIT

SLACK ADJUSTER PULLER (PART # 10406)

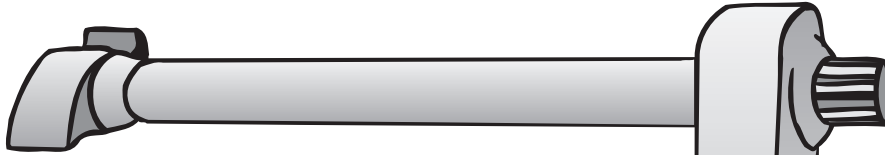

OPERATING INSTRUCTIONS

- 1) Remove Clevis from the end of the Slack Adjuster with the Tiger Brake Clevis Pin Press (Part #10501).
- 2) With the forcing screw backed out, slip the puller onto the Slack Adjuster.
- 3) Turn the forcing screw by hand or with an impact wrench.
- 4) Slack Adjuster will drop off when free.

Do not use over ½ inch impact wrench. Doing so will void warranty.

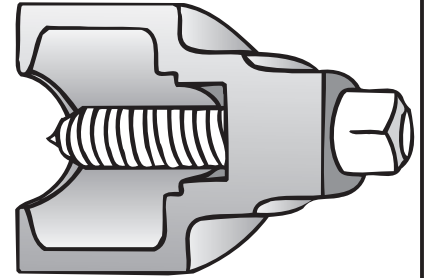

Stay Alert! Watch what you are doing and use common sense when operating this tool. Do not operate tool while under the influence of drugs, alcohol, or medication. Always use safety equipment to prevent injuries. Approved face and eye protection must always be worn by the operator, as well as others in the work area. Keep your work area clean and well lit.

SLACK ADJUSTER PULLER (PART # 10407)



OPERATING INSTRUCTIONS

- 1) Remove Clevis from the end of the Slack Adjuster with the Tiger Brake Clevis Pin Press (Part #10501).
- 2) With the forcing screw backed out, slip the puller onto the Slack Adjuster.
- 3) Attach tool to Slack Adjuster through clevis hole and tighten.
- 4) Turn the forcing screw by hand or with an impact wrench.
- 5) Slack Adjuster will drop off when free.

Do not use over ½ inch impact wrench. Doing so will void warranty.

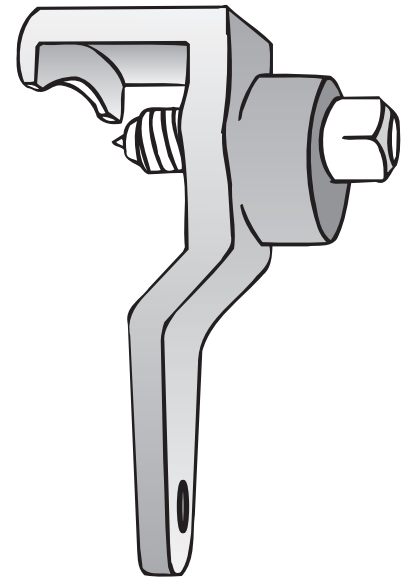
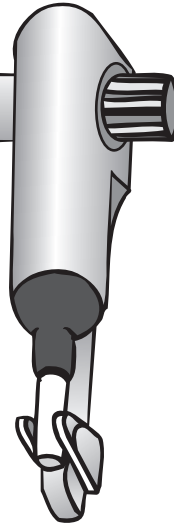

Lubrication: Use any quality oil on threads (not anti-seize) and any quality grease on load bearing surface in glove, under black plastic cap. For more information, please call us at 1-800-661-4661.

TIGER TOOL International Incorporated®

Phone: 1-800-661-4661