



**Electro-Hydraulic / UTV Frame Lift**

**UF-2200EH-X**

Capacity 2,200lbs



**Installation, Operation & Maintenance  
Manual**

# CONTENTS

## **1. Safety Information**

- 1.1 Note, Caution and Warning
- 1.2 Important Information
- 1.3 Safety Instructions
- 1.4 Caution and Warning Labels

## **2. Technical Specifications**

- 2.1 Product Description
- 2.2 Product Specifications
- 2.3 Hydraulic Schematic
- 2.4 Circuit Diagram

## **3. Preparing and Installation**

- 3.1 Site Selection
- 3.2 Surface Condition / Foundation & Anchoring
- 3.3 Necessary Tools
- 3.4 Personal Protective Equipment
- 3.5 Set-Up & Installation

## **4. Operation**

- 4.1 Operation Instructions

## **5. Maintenance Instructions**

## **6. Exploded Views & Parts Lists**

## **7. Trouble Shooting Guide**

## **8. Limited Warranty**

# 1. Safety Information

## 1.1 Note, Caution and Warning

This document uses the following conventions- **Note, Caution and Warning** . to alert you to special instructions, tips, or hazards for a given procedure. Please familiarize yourself with the conventions described below.

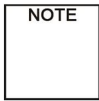

**Indicates important information that requires special attention, such as a procedure for a specific vehicle, or tips on operating the equipment.**



**Indicates the potential for damage to equipment, accessories, or the vehicle unless you follow the instructions or procedure exactly.**



**Indicates the potential for property damage, personal injury, or death due to hazards associated with the equipment, vehicle, or environment. Do not perform any procedure until you have read and understood the warning instructions.**

## 1.2 Important Information

1. Carefully read this manual thoroughly before installing, operating, or maintaining this lift.
2. This lift is designed for indoor use only.
3. The lift has specific electrical requirements as described in the Installation Instructions section of this manual.
4. Failure by the owner to provide the **recommended shelter, mounting surface, electrical supply, and ceiling height** could result in unsatisfactory lift performance, property damage, or personal injury.
5. The operation of the lift is permitted by authorized person only.
6. Keep this guide as well as all the supplied technical literature in a safe place close to the lift so that operators are able to read it whenever necessary.
7. If any confusion, please contact the service provider or your distributor.

## 1.3 Safety Instructions

1. **Do not** raise a vehicle on the lift until the initialization is completed as described in this manual.
2. Technicians should be trained to use and care for the lift by familiarizing themselves with the publications listed above. The lift should **never be operated by an untrained person**.
3. **Do not overload the lift**. The capacity of the lift is shown on cover of this document and on the lift's serial number tag.
4. Positioning the vehicle is very important. Only trained technicians should position the vehicle on the lift. **Never allow anyone to stand in the path of the vehicle as it is being positioned and never raise vehicle with passengers on vehicles.**

5. Keep everyone clear of the lift when the lift is moving, the locking mechanism is disengaged, or the vehicle is in danger of falling.
6. Unauthorized personnel should never be in the shop area when the lift is in use.
7. Inspect the lift daily. **The lift should never be operated if it has damaged components, or is malfunctioning.** Only qualified technicians should service the lift. **Replace damaged components with manufacturer's parts, or equivalent.**
8. **Keep the area around the lift clear of obstacles.**
9. **Never override the self-returning lift controls.**
10. Avoid excessive rocking of the vehicle when it is on the lift.
11. To reduce the risk of personal injury, keep hair, loose clothing, fingers, and all body parts away from moving parts.
12. To reduce the risk of electric shock, **do not** use the lift when wet, do not expose the lift to rain.
13. To reduce the risk of fire, **do not** operate equipment in the vicinity of open containers of flammable liquids (gasoline).
14. Use the lift only as described in this manual, **use only manufacturer's recommended attachments.**
15. The maintenance procedures described in this manual can be done by the lift's owner/employer. Any other procedure should only be performed by trained lift service personnel. **These restricted procedures include, but are not limited to, the following: cylinder replacement, platform & safety latch replacement, motor replacement, oil replacement / refilling and lubrication.**
16. Anyone who will be in the vicinity of the lift when it is in use should familiarize themselves with following Caution, Warning, and Safety related decals supplied with this lift, and replace them if they are illegible or missing.
17. Never move the lift when the vehicle is loaded.
18. Only use on a level concrete surface with a recommended minimum thickness of 4+. **DO NOT** install on an asphalt surface.
19. Only remove the vehicle when the lift platform is at the lowest position.
20. Never lift the vehicle with persons riding on it.

## 1.4 Caution and Warning Labels

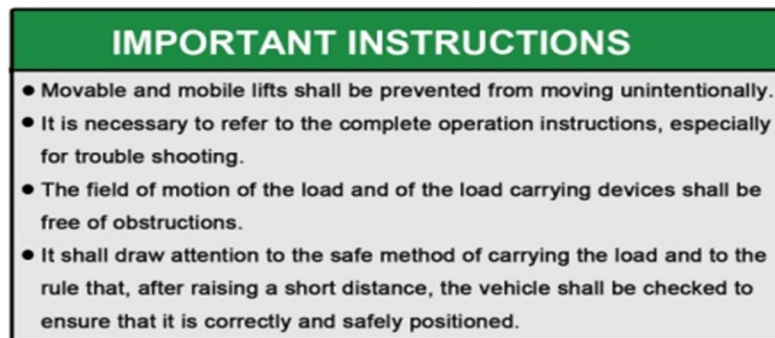
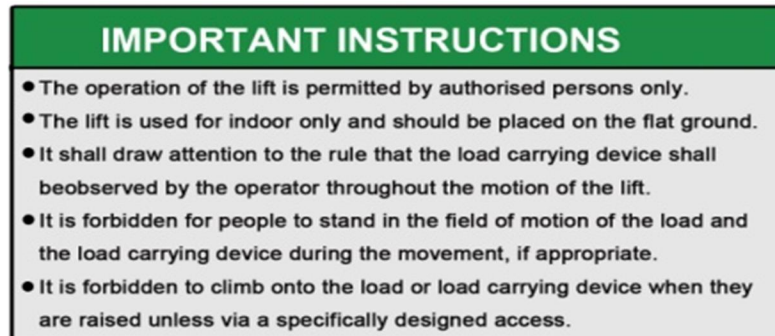

## 2. Technical Specification

### 2.1 Product Description

The UF-2200EH-X UTV Frame Engaging Platform Lift provides 4 wheels free service designed for repairing, customizing and maintaining UTVs, ATVs & Golf Carts using a 110VAC-60Hz, 1Ph power source, all while incorporating the latest safety technologies. The UF-2200EH-X is designed and manufactured for a max lifting capacity of 2,200 lbs. (1,000kg), and is fully capable for lifting most all large UTVs, ATVs & Golf Carts on the market today, while safely holding them in an elevated, locked height position.

The electro-hydraulic UTV Lift consists of a fixed structural scissor platform lift, (portable or mounted) pedestal control stand & rubber height adaptors. Full lift operation is controlled from the Control Panel.

### 2.2 Product Specifications - UF-2200EH-X

Capacity	2,200 lbs. (1,000 kg)
Min. Height	4.75" (121 mm)
Max Lifting Heights	43" (1092 mm) to 49.25+(1251 mm) w/ Adaptor
Locking Heights	28+- 36.5+- 42+(711 - 927 - 1067 mm)
Overall Length w/ Ramps	67" to 89" (1702 - 2261 mm)
Overall Width	24.8" (630 mm)
Platform Size (L x W)	67+x 24" (1702 x 610 mm)
Pedestal Control Stand Size (L x W x H)	15+x 11+x 39+(381 x 279 x 991 mm)
Pedestal / Platform Max Distance	96+(2438 mm)
Lifting Time	25 S
Lowering Time	25 S
Power	110V, 60Hz, 1 PH-18A
Ship Weight	740 lbs.

# UF-2200EH-X Dimension Drawings

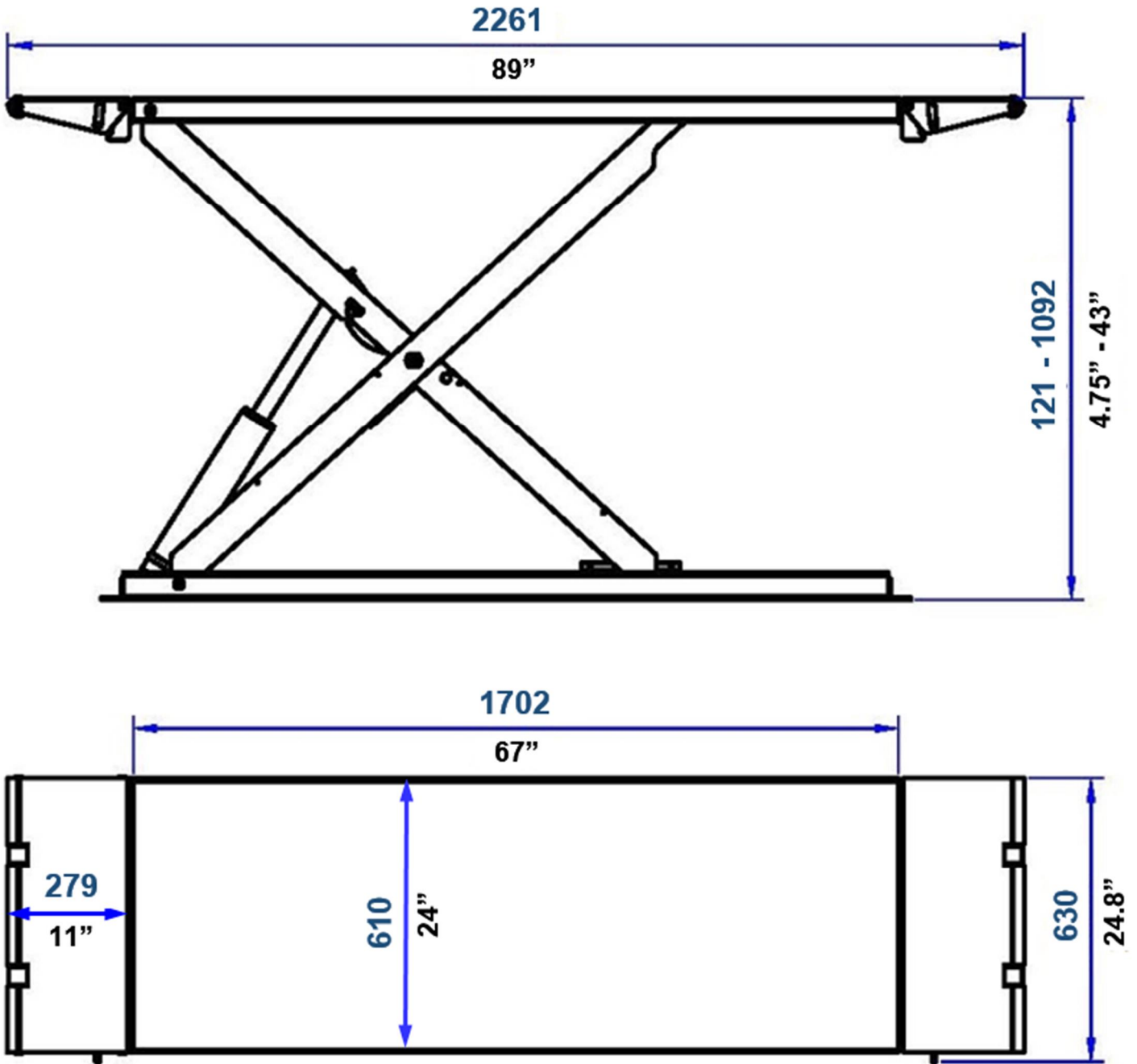

### 2.3 Hydraulic Schematic

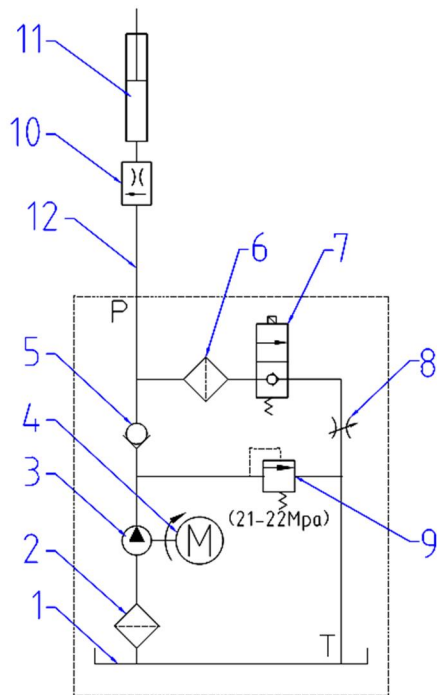

1	MOTOR
2	FILTER
3	GEAR PUMP
4	SINGLE-WAY VALVE
5	CYLINDER

6	FLOW VALVE
7	FILTER
8	RELEASE VALVE
9	OVER-FLOW VALVE
10	OIL TANK

### 2.4 Circuit Diagram

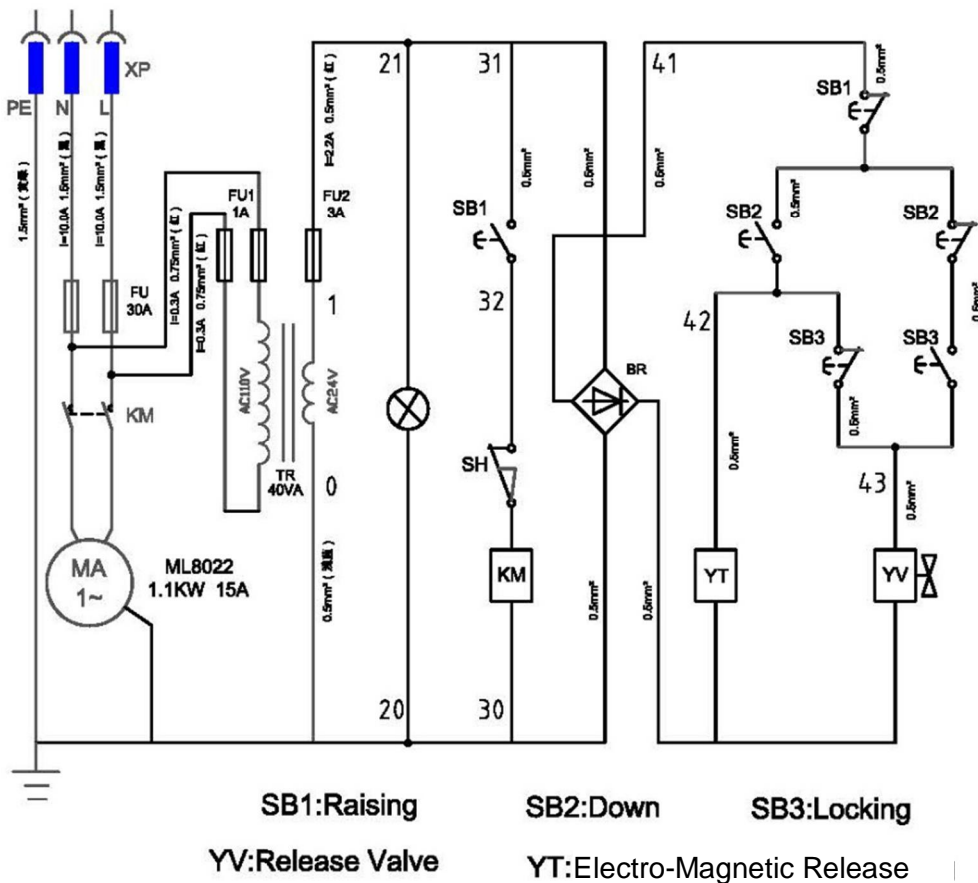

XP	POWER CORD W/ PLUG	1
QS	POWER SWITCH	1
FU	POWER FUSE, DELAY 25A	2
TC	TRANSFORMER	1
FU1	TRANSFORMER FUSE, DELAY 1.0A	2
SB1	UP BUTTON	1
SH	UPPER LIMIT SWITCH	1
KM	CONTACTOR	1
SB3	STOP BUTTON	1
YV	RELEASE VALVE, 24VDC	1
SB2	DOWN BUTTON	1
YT	ELECTRO-MAGNET, 24VDC	1
M	MOTOR 110V, 60Hz, 1Ph	1



### 3. Preparing and Installation

#### 3.1 Site Selection

The hydraulic UTV lift is designed only for indoor use. Application in a room with explosion hazard is not recommended. Setting in a wet place, a car wash bay for instance, is also not recommended. Make sure to check the desired location for possible obstructions such as a low ceiling, overhead lines, adequate working area, access ways, exits, etc.

#### 3.2 Surface Condition / Foundation & Anchoring

The UF-2200EH-X hydraulic frame lift should be installed on level surface. **The foundation must be 4" minimum thickness concrete, with a minimum compressive strength of 3,000 psi.** Failure to meet the foundation requirement may cause the lift instability or personal injury. There should also be no floor seam under end ramps roller locations. Installing on asphalt, soft clay floor or near the expansion gap is prohibited.

### FOUNDATION and ANCHORING REQUIREMENTS

1. Concrete shall have compression strength of at least 3,000 PSI and a minimum thickness of 4+in order to achieve a minimum anchor embedment of 3.0+. NOTE: When using the standard supplied 3/8+x 3-3/4+long anchors, if the top of the anchor exceeds .5+above the floor grade, you DO NOT have enough embedment.
2. Maintain a 6+minimum distance from any slab edge or seam. Hole to hole spacing should be a minimum 6+in any direction. Hole depth should be a minimum of 4+
3. DO NOT install on asphalt or other similar unstable surface.
4. Using the horseshoe shims provided, shim each corner of base as required until base is level.
5. Torque anchors to 50 ft-lbs. Shim thickness MUST NOT exceed 1/4+when using the 3-3/4+long anchors provided with the lift.
6. If anchors do not tighten to 50 ft-lbs. installation torque, it's recommended to replace the concrete under base with a 4qx 4qx 6+thick 3,000 PSI minimum concrete pad keyed under and flush with the top of existing floor. Allow concrete to cure before installing lifts and anchors (typically 2 to 3 weeks).

### ANCHORING TIPS

1. Use a concrete hammer drill with a carbide tip, solid drill bit the same diameter as the anchor shield, 5+- (.50 to .55 inches diameter). Do not use excessively worn bits or bits which have been incorrectly sharpened.
2. Keep the drill in a perpendicular line while drilling.
3. Let the drill do the work. Do not apply excessive pressure. Lift the drill up and down occasionally to remove residue to reduce binding.
4. For better holding power blow dust from the hole.
5. Carefully tap anchor into hole. Do not damage threads. Tap anchor into the concrete until anchor hex nut and flat washer are against base plate. Do not use an impact wrench to tighten!
6. Tighten the anchor hex nut until tightened to 50 ft-lbs. torque.



**Failure in accomplish the foundation requirement may cause the lift instability or personal injury. Installing on asphalt, soft clay floor or near the expansion gap is prohibited.**

### 3.3 Necessary Tools & Supplies

- Forklift & Soft Sling Straps (recommended)
- 115VAC, 60 Hz, 20 Amp Service
- 6 Quarts of Non-Detergent / Non-Foaming Hydraulic Oil - SAE-10, AW 32 or equivalent
- Chalk Line
- Tape Measure
- Level
- Metric Wrenches & Sockets
- Adjustable Wrench
- Cross Head Screw Driver
- Oil Funnel
- Hammer Drill with 1/2+Carbide Drill Bit
- Gloves

### 3.4 Personal Protective Equipment

Always wear proper protective equipment like proper clothing, shoes, gloves & safety glasses, etc.

### 3.5 Set-Up & Installation

#### 1. Unpacking

- a. Carefully open crate and remove loose parts & components from top of lift structure.
- b. Using a forklift (recommended) carefully remove lift from crate and place in the desired location (**Fig.1**).  
**NOTE: Ensure to check packing list to make certain all parts are included and in good condition.**



**Fig.1**

#### 2. Assembly (Pedestal Control Stand & Power Unit)

- a. Using the Exploded View Diagram on Page 20 as a guide, assemble the components for Pedestal Control Stand using the hardware provided. **NOTE: Do not mount the Power Unit or Cover at this time.**
- b. Carefully mount the Control Panel to top plate located at the top of Pedestal Stand, as detailed in the Parts List and Exploded View Diagram. **NOTE: Ensure not to damage Wiring Harness or Plug Connectors.**

- c. Mount Power Unit to the Pedestal Control Stand assembly, using Bolts, Flat Washers & Lock Nuts ensuring the Back Plate is already secured to the Stand.
- d. Ensure to tighten all Nuts & Bolts for Pedestal Control Stand assembly.

### 3. Power Unit - (Filling Reservoir Tank)

- a. Remove the red vent plug (Fig.2) from the power unit reservoir tank and fill with hydraulic oil. Add oil until level reaches the Minimum fill line noted on Reservoir Tank.

**NOTE: Use Non-Detergent / Non-Foaming Hydraulic Oil - SAE-10, AW 32 or equivalent. The unit holds approximately six quarts of fluid. Make sure the funnel used to fill the power unit is clean.**



**Fig.2**

### 4. Control Panel Connections - (Power Unit, Release Valve & Latches)

- a. Locate the Control Panel & Wiring Harness assembly (Figs.3 & 4) and carefully route Wiring Harness through the backside of the Stand & Back Plate lower left hand port, as shown in Fig.5.



**Fig.3**

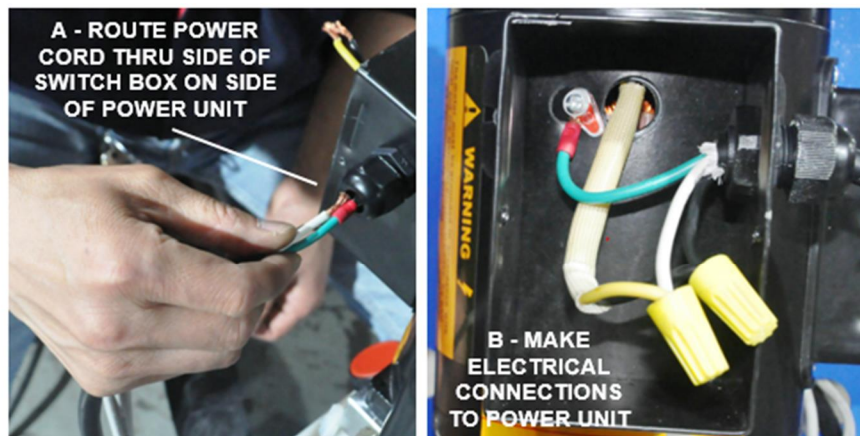

**Fig.4**



**Fig.5**

- b. Route Power Cord to the Power Unit & Switch Box and make electrical connection, as detailed in Fig.6.



**Make 110V Electrical Wiring Connections as follows: (Black to Black) - (White to Yellow) - (Green to Ground Screw)**

**Fig.6**

- c. Make electrical plug wiring connection for the Electro-Matic Release Valve, by locating the Plug E from Wiring Harness and matching Plug E connector from the power unit's Electro-Matic Release Valve's wiring harness, as shown below in **Fig. 7**. **NOTE: Ensure plug connectors are securely locked together.**
- d. Using the Wiring Harness from Frame Lift & Wiring Harness from Control Panel, make electrical plug connections for the Electro-Matic Lift Latches, by locating the Plugs C from both wiring harnesses. Connect together, as shown below in **Fig.7**. **NOTE: Ensure both plug connectors are securely locked together.**
- e. Using the Wiring Harness from Frame Lift and the 90 degree Fitting for Power Unit, make Hydraulic Hose connection to Power Unit. Secure hydraulic hose to 90 degree fitting, shown below in **Fig.7**. **NOTE: Ensure hydraulic fitting connections are properly tightened together but DO NOT overtighten.**

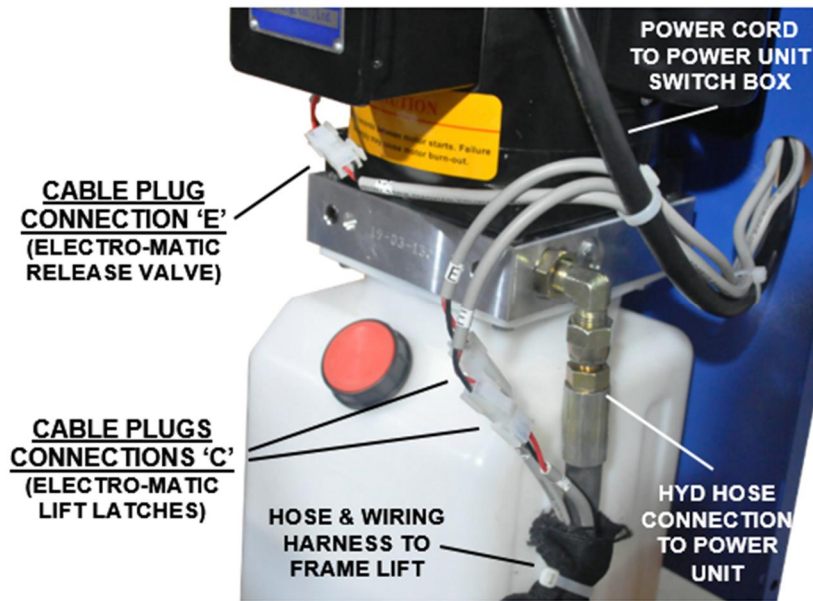

**Fig.7**

## 5. Main Power Connection



Before power connection is made, check power supply outlet to ensure it's in accordance with the requirements of the lift.

- a. Connect lift's electrical plug to an 110V-60Hz, 1Ph, 20A power supply outlet (**Fig.8**).



Protection against power surges shall be provided by the user.

**NOTE: If using an extension cord, ensure to use extension cord rated for 20 amps.**



**Fig.8**

## 6. Anchoring Lift & Pedestal Stand

- a. Once Lift & Pedestal Stand placement locations are confirmed, install anchor bolts at each corner of Lift to secure to floor, referencing the **FOUNDATION and ANCHORING REQUIREMENTS** info. on **Page 9**.  
**NOTE: Anchor Pedestal to floor is optional. Fig.10**

## 7. Starting Up (No Load on Lift)

- a. Using the Control Panel, first turn of the red Emergency / Master Power Switch for lift operation.
- b. Raise the lift platform to full height by pressing the **(GREEN) UP ↑** button. **(Fig. 9)**
- c. Lower the lift to floor by pressing the **(BLUE) DOWN ↓** button.
- d. With no load on lift, cycle up and down 2 or 3 times to bleed air out of the hydraulic system. **(Wait 2 minutes between lift cycles)**
- e. After cycling lift, raise and test latching operation by raising lift to full height, followed by pressing the **(BLACK) LOCK / STOP-DESCENT** button, which will lower the lift to the next locked height position.
- f. To lower lift from locked height position, press the **(GREEN) UP ↑** for just 1 to 2 seconds, followed by pressing the **(BLUE) DOWN ↓** button until lift to lowers to floor.



Fig.9

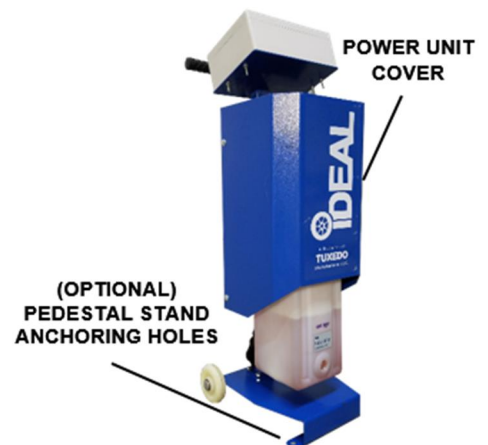

Fig.10

- g. During ~~S~~Start Up procedure, double check for proper lift operation and for any hydraulic leaks. Once confirmed for proper lift operation and no apparent hydraulic leaks, install the Power Unit Cover to Pedestal Control Stand using the Screws provided. **Fig.10**



**The Lift is now ready for Operation**

## 4. Operation

Be sure to read and familiarize yourself with the Safety Instructions at the beginning of this manual. Be sure to wear gloves, protection glasses and all necessary personal protective equipment. Failure to follow Safety Instructions may result in property damage, personal injury or death.

### 4.1 Operating Instructions



**Be sure to read and familiarize yourself with the Safety Instructions at the beginning of this manual. Failure to follow Safety Instructions may result in property damage or personal injury.**



**To avoid personal injury and/or property damage, permit only trained personnel to operate lift.**

#### 1. Lift Preparation:

- Lift must be fully lowered and area clear of all personnel before vehicles are placed on lift.

#### 2. Loading Lift:

- Carefully drive vehicle over fully lowered Frame Lift while keeping the vehicle centered left to right while aligning the center of gravity of the vehicle front to back to the frame lift platform. If rubber contact pads are required, ensure to place contact pads at proper lift points able to support vehicle.



**It is recommend to slightly raise vehicle to check vehicle stability on lift before fully raising.**

#### 3. To Raise Lift & Lock

- a. Push **(GREEN) UP** ↑ button on the Control Panel.
- b. Raise vehicle to the desired height, then release the **(GREEN) UP** ↑ button.
- c. Push the **(BLACK) PARKING** button to lower the vehicle onto the locking position, as the locking latches will automatically engage.

#### 4. (Emergency Switch)

- a. The lift can also be switched off immediately by turning the **(RED) Emergency** Switch on Control Panel.



**When any emergency situation comes, turn the emergency switch knob immediately to stop the lift. When emergencies are resolved, reset the switch to disengage the emergency stop mode.**

#### 5. To Lower Lift



**Check all danger points of the lift and be sure that there are no tools, objects or people in the working area (danger area) around the lift or under the lift before lowering.**

- a. If the lift is already in the locked position (latches are engaged), press the **(GREEN) UP** ↑ button to raise the lift a short distance to disengage the latch mechanisms.

- b. Then press **(BLUE) DOWN** ↓ button on remote controller to lower lift to the floor, while observing the complete lowering process to check for any unexpected movement.
- c. After lift is fully lowered to floor, carefully remove the vehicle from frame lift platform.



**Remain clear of lift when lowering vehicle. Observe pinch point warning decals.**

**If lift is not operating properly, DO NOT use until adjustment or repairs are made by qualified lift service personnel.**



**DO NOT use the (BLACK) LOCK button instead of the (BLUE) DOWN button to fully lower.**



**NEVER press the UP or DOWN button for a long time while the lift is not moving, or the control system will be damaged. Release button if you find the lift is not properly responding.**



**Once finished with lift operation, engage the Emergency / Master Switch button to cut off main power and unplug the lift is recommended.**



**If any unsafe movement of the lift occurs, do not to operate the lift and call the local distributor for assistance.**

## 5. Maintenance Instructions

Contact your service provider for instructions before starting up if you are not completely familiar with lift maintenance procedures. Only qualified personnel can perform maintenance on this equipment. Any failure in operation may cause personal injury and/or damage to lift.

### Daily:

- ✓ Wear necessary protective equipment before use, includes, but not limited, gloves and protection glasses, working suits and shoes.
- ✓ Always keep bolts tight. Check periodically.
- ✓ Always keep lift components clean.
- ✓ If oil leakage is observed, contact your service provider.
- ✓ Check safety latches for free movement and full engagement with lift are properly working
- ✓ Check hoses connections for leakage.

### Every Month:

- ✓ Lubricate locking latch shafts & pivot points. Push latch handle several times for oil to penetrate joints.
- ✓ Lubricate the sliding pieces with heavy duty bearing grease.
- ✓ With lift lowered check the hydraulic fluid level. If necessary add oil as described in the Installation Instruction section of this manual
- ✓ Check platform latch synching: Latches should click at the same time.
- ✓ Check tightness of all bolts.
- ✓ Check the nuts for tightness every week for the first month, and every month afterwards.

### Every 6 Months:

- ✓ Check and clean the oil filter, if applies.
- ✓ Check the hydraulic oil for proper level with lift in down position. Refill reservoir tank with hydraulic oil if necessary with AW 32 or AW46 Non-Detergent Non-Foaming Anti-Wear Hydraulic Oil.
- ✓ If Lift stops short of full rise or chatters, contact your service provider.
- ✓ Replace all caution, warning or safety related decals on the lift if unable to read or missing. Reorder labels from service provider.
- ✓ Check all components for wear.



## 6. Exploded Views & Parts Lists

### Exploded Views – (Lift Structure)

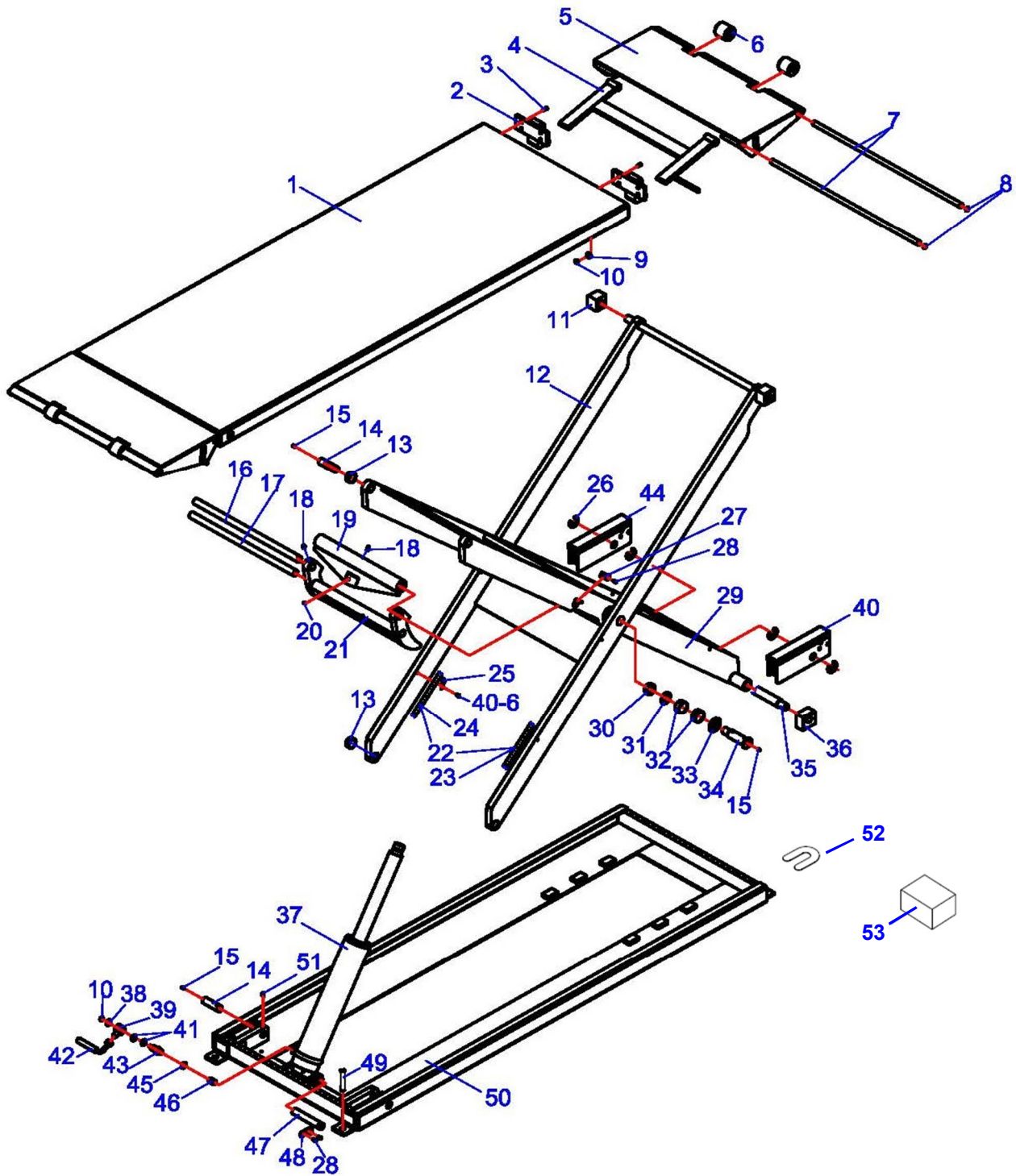

## Exploded Views – (Lift Structure)

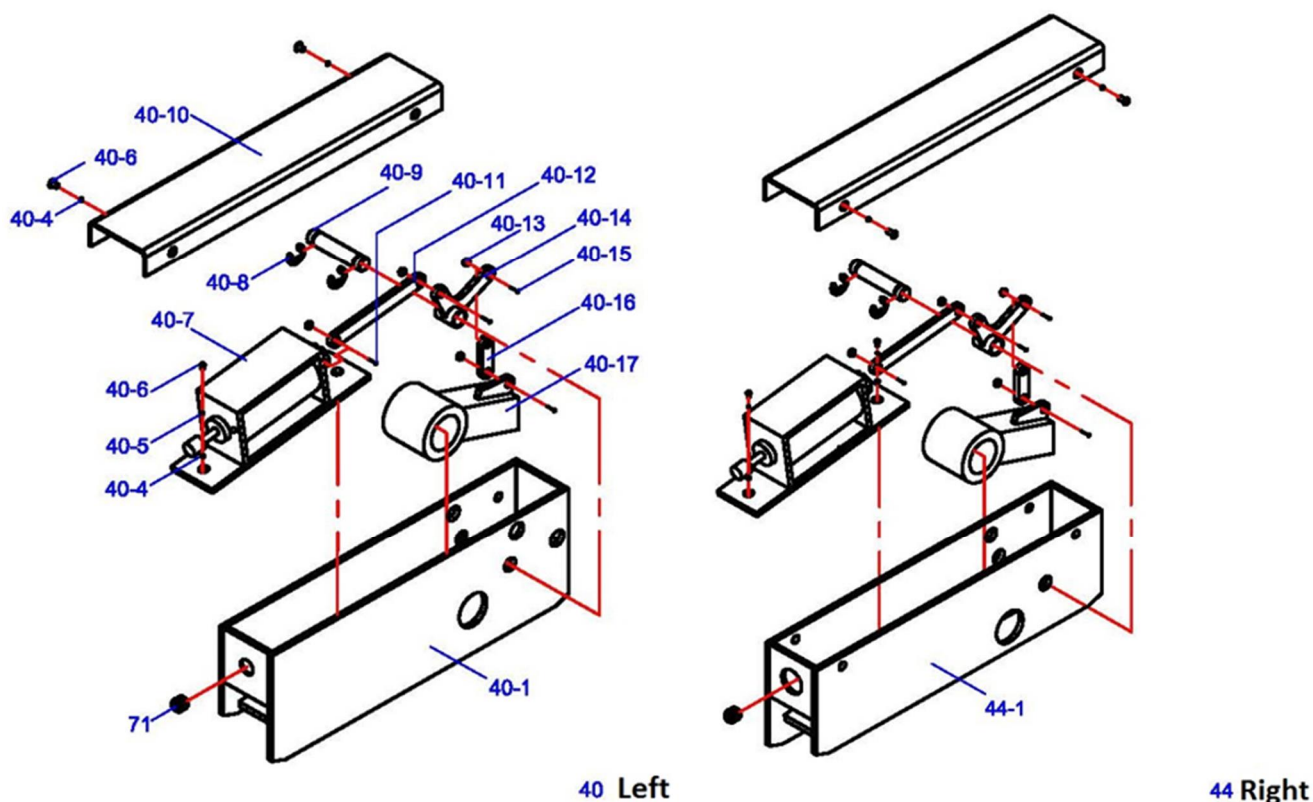

## Parts List – (Lift Structure)

ITEM	Tux P/N	M-Ref P/N	DESCRIPTION	QTY
1	UF-2200EHX-001	JP26-01000-000	Platform	1
2	UF-2200EHX-002	JP26-10000-000	Ramp Block	4
3	UF-2200EHX-003	5120-08025-000	Screw, M8 x 25mm	16
4	UF-2200EHX-004	JP26-09000-000	Ramp Bracket	2
5	UF-2200EHX-005	JP26-08000-000	Ramp	2
6	UF-2200EHX-006	JP16-12108-000	Roller	4
7	UF-2200EHX-007	JP26-00001-000	Roller Pin	4
8	UF-2200EHX-008	5304-00014-000	Circlip, D14	8
9	UF-2200EHX-009	5302-00008-000	Flat Washer, D8	16
10	UF-2200EHX-010	5206-00008-000	Lock Nut, M8	17
11	UF-2200EHX-011	JP26-00003-000	Upper Slide Block	2
12	UF-2200EHX-012	JP26-03000-000	Outer Scissor Frame	1
13	UF-2200EHX-013	5603-20020-000	Bearing, D20 x 20mm	4
14	UF-2200EHX-014	JP26-00002-000	Pivot Pin	4
15	UF-2200EHX-015	SJ05-HYZ00-000	Grease Zerk, M8	6
16	UF-2200EHX-016	JP26-00005-000	Shaft #1	1
17	UF-2200EHX-017	JP26-00011-000	Shaft #2	1
18	UF-2200EHX-018	JP02-00007-000	Grease Zerk, M6	5
19	UF-2200EHX-019	JP26-07000-000	Cylinder Pivot Bracket	1
20	UF-2200EHX-020	5109-06010-000	Threaded Pin, M6 x 10mm	1
21	UF-2200EHX-021	JP26-06000-000	Assist Bracket	1

22	UF-2200EHX-022	JP26-00010-000	Cable Spring Cover	4
23	UF-2200EHX-023	JP26-50001-A00	Valve Cable #1 (210.6+)	1
24	UF-2200EHX-024	JP26-50002-A00	Valve Cable #2 (197+)	1
25	UF-2200EHX-025	JP24-00009-000	Lock Plate	10
26	UF-2200EHX-026	5305-00024-000	Circlip	4
27	UF-2200EHX-027	JP24-00032-000	Limit Plate	1
28	UF-2200EHX-028	5105-06012-000	Screw, M6 x 12mm	4
29	UF-2200EHX-029	JP26-02000-000	Inner Scissor Frame	1
30	UF-2200EHX-030	5206-00020-000	Lock Nut, M20	2
31	UF-2200EHX-031	5302-00020-000	Flat Washer, D20	2
32	UF-2200EHX-032	5603-25030-000	Bearing, D25 x 30mm	4
33	UF-2200EHX-033	5302-00025-000	Flat Washer, D25	2
34	UF-2200EHX-034	JP26-00006-000	Bolt	2
35	UF-2200EHX-035	JP26-00009-000	Inner Frame Axle	1
36	UF-2200EHX-036	JP26-00004-000	Lower Slide Block	1
37	UF-2200EHX-037	JP26-04000-000	Cylinder	1
38	UF-2200EHX-038	JP22-00017-000	Circlip	1
39	UF-2200EHX-039	JP26-00012-000	Quick Connector	1
40	UF-2200EHX-040	JP24-14000-000	Safety Latch (LH)	1
40-1	UF-2200EHX-040.1	JP24-14100-000	Latch Frame (LH)	1
40-4	UF-2200EHX-040.4	5302-00005-000	Flat Washer, D5	8
40-5	UF-2200EHX-040.5	5303-00005-000	Lock Washer, D5	4
40-6	UF-2200EHX-040.6	5110-05012-000	Screw, M5 x 12mm	18
40-7	UF-2200EHX-040.7	MK01-03000-000	Electromagnet	2
40-8	UF-2200EHX-040.8	5305-00006-000	Circlip, D6	4
40-9	UF-2200EHX-040.9	JP24-13003-000	Latch Pin	3
40-10	UF-2200EHX-040.10	JP24-00016-000	Latch Cover	2
40-11	UF-2200EHX-040.11	5110-04020-000	Screw, M4 x 20mm	2
40-12	UF-2200EHX-040.12	JP24-13001-000	Linkage Arm - Long	2
40-13	UF-2200EHX-040.13	5206-00004-000	Lock Nut, M4	8
40-14	UF-2200EHX-040.14	JP24-13200-000	Rocker Arm	2
40-15	UF-2200EHX-040.15	5110-04012-000	Screw, M4 x 12mm	6
40-16	UF-2200EHX-040.16	JP24-13002-000	Linkage Arm - Short	2
40-17	UF-2200EHX-040.17	JP24-13300-000	Latch	2
41	UF-2200EHX-041	5901-13018-000	O-Ring, D13 x 1.8mm	2
42	UF-2200EHX-042	JP26-00013-000	Hydraulic Hose	1
43	UF-2200EHX-043	JP27-00008-000	Fitting Connector	2
44	UF-2200EHX-044	JP24-13000-000	Safety Latch (RH)	1
44-1	UF-2200EHX-044.1	JP24-13100-000	Latch Frame (RH)	1
45	UF-2200EHX-045	5903-00014-000	Combined Washer, D14	1
46	UF-2200EHX-046	JP24-04005-000	Compensating Valve	1
47	UF-2200EHX-047	JP26-00007-000	Cylinder Pin	1
48	UF-2200EHX-048	JP26-00008-000	Cylinder Pin Plate	1
49	UF-2200EHX-049	JP26-10080-000	Anchor Bolt 1/2" x 3-3/4+	4
50	UF-2200EHX-050	JP26-05000-000	Base Frame	1
51	UF-2200EHX-051	5112-10016-000	Threaded Pin, M10 x 16mm	4
52	UF-2200EHX-052	NA	U-Shim	10
53	UF-2200EHX-053	JP09-00008-000	Rubber Contact Pads	4

## Exploded View – (Pedestal Control Stand)

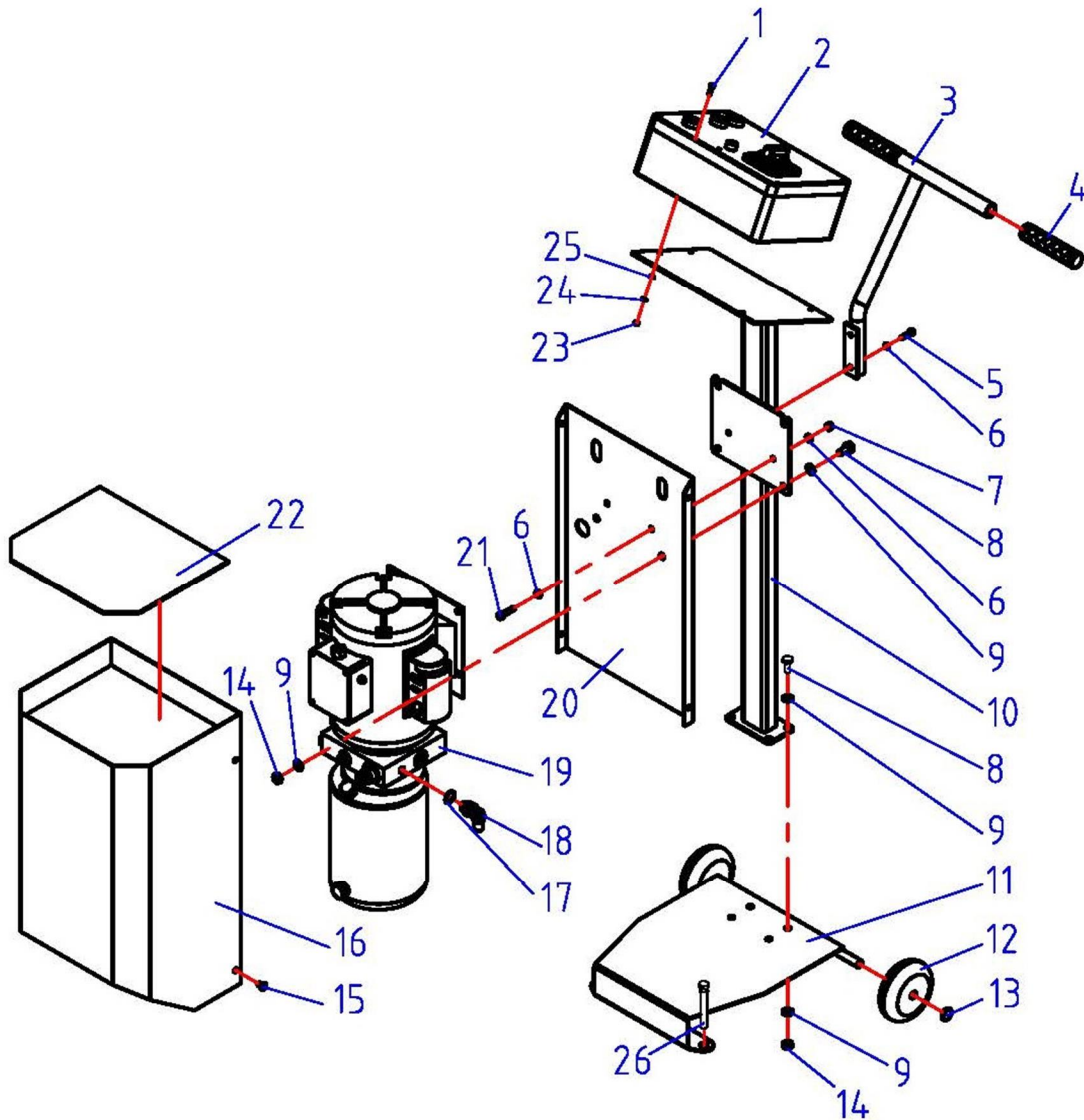

## Parts List – (Pedestal Control Stand)

ITEM	Tux P/N	M-Ref P/N	DESCRIPTION	QTY
1	UF-2200EHX-PS-001	5110-04016-000	Screw	4
2	UF-2200EHX-PS-002	JP260S-243154	Control Panel	1
3	UF-2200EHX-PS-003	XC26-03000-000	Handle	1
4	UF-2200EHX-PS-004	ES04-00009-000	Rubber Cover	2
5	UF-2200EHX-PS-005	5112-06030-000	Screw	2
6	UF-2200EHX-PS-006	5302-00006-000	Flat Washer	6
7	UF-2200EHX-PS-007	5206-00006-000	Lock Nut	2
8	UF-2200EHX-PS-008	5101-08025-000	Bolt	8
9	UF-2200EHX-PS-009	5302-00008-000	Flat Washer	16
10	UF-2200EHX-PS-010	XC26-01000-000	Pedestal Stand	1
11	UF-2200EHX-PS-011	XC26-02000-000	Pedestal Base	1

12	UF-2200EHX-PS-012	XC26-00003-000	Wheel	2
13	UF-2200EHX-PS-013	JP16-26001-000	Wheel Nut	2
14	UF-2200EHX-PS-014	5206-00008-000	Lock Nut	8
15	UF-2200EHX-PS-015	5115-06012-000	Screw	4
16	UF-2200EHX-PS-016	XC26-04000-000	Power Unit Cover	1
17	UF-2200EHX-PS-017	5901-10002-000	O-Ring	2
18	UF-2200EHX-PS-018	SJ01-12001-000	Hyd. Elbow Fitting	2
19	UF-2200EHX-PS-019	JP260S-243154	Power Unit - 110V-1PH, 60Hz	1
20	UF-2200EHX-PS-020	XC26-00001-000	Back Plate	1
21	UF-2200EHX-PS-021	5110-06016-000	Screw	2
22	UF-2200EHX-PS-022	XC26-00002-000	Rubber Pad	1
23	UF-2200EHX-PS-023	5201-00004-000	Nut	4
24	UF-2200EHX-PS-024	5303-00004-000	Lock Washer	4
25	UF-2200EHX-PS-025	5302-00004-000	Flat Washer	4
26	UF-2200EHX-PS-026	JP26-10080-000	Anchor Bolt 1/2" x 3-3/4+(Opt)	2

## Exploded View – (Control Panel)

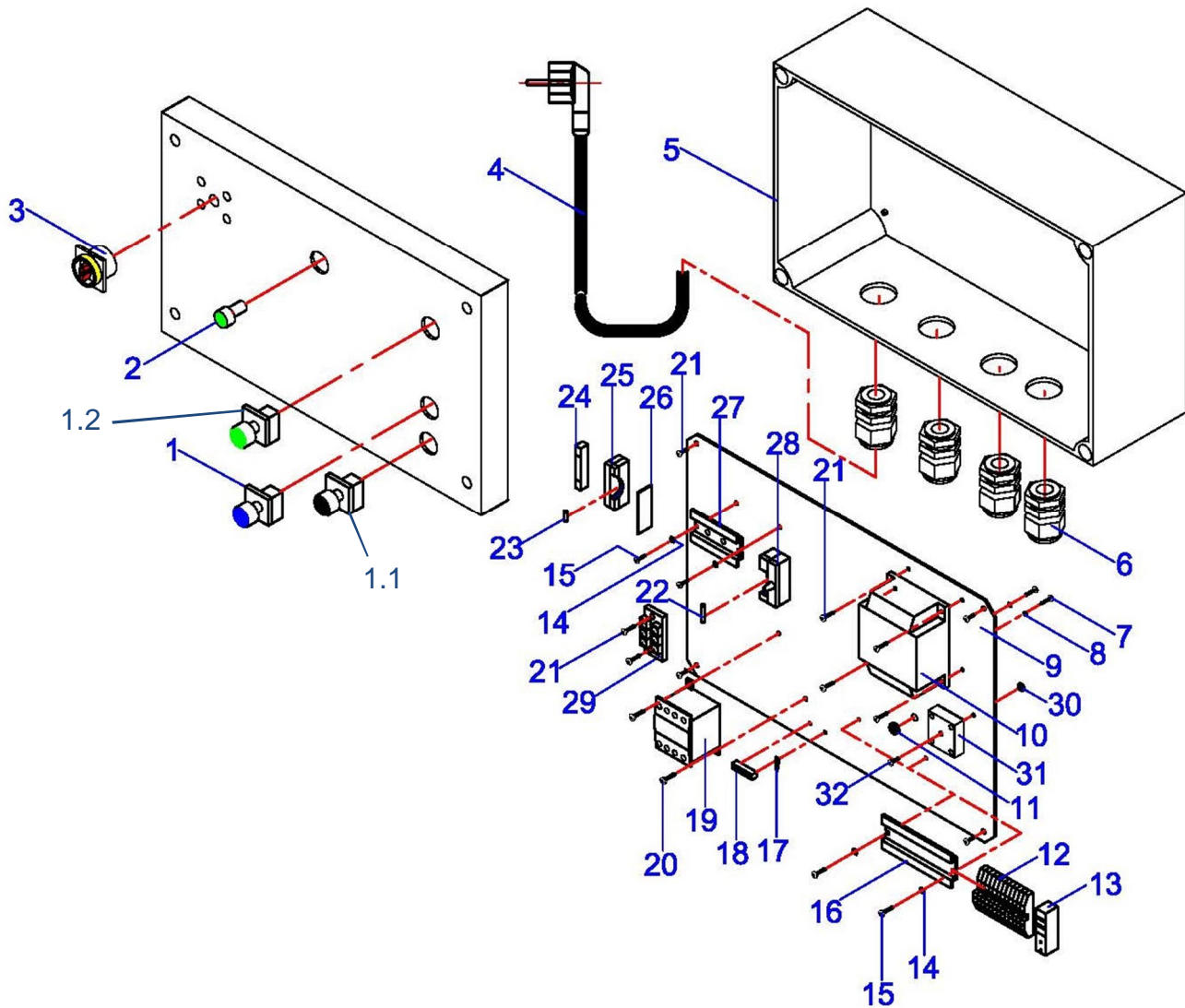

## Parts List – (Control Panel)

ITEM	Tux P/N	M-Ref P/N	DESCRIPTION	QTY
1	UF-2200EHX-CP-001	JK01-20002-000-BLU	Down Button (Blue)	1
1-1	UF-2200EHX-CP-001.1	JK01-20002-000-BLK	Park Button (Black)	1
1-2	UF-2200EHX-CP-001.2	JK01-20002-000-GRN	Up Button (Green)	1
2	UF-2200EHX-CP-002	JK11-00100-K00	Green Indicator Light	1
3	UF-2200EHX-CP-003	DK09-00005-000	Main Power Switch	1
4	UF-2200EHX-CP-004	MK01-00002-B00	Power Cable 110V	1
5	UF-2200EHX-CP-005	JK01-00001-000	Control Box Shell	1
6	UF-2200EHX-CP-006	JK01-00004-000	Cable Nut	4
7	UF-2200EHX-CP-007	5110-04004-000	Screw, M4 x 4mm	2
8	UF-2200EHX-CP-008	5301-00004-000	Flat Washer, D4	2
9	UF-2200EHX-CP-009	JK03-10001-000	Mount Plate	1
10	UF-2200EHX-CP-010	JK04-10006-A00	Transformer	1

11	UF-2200EHX-CP-011	JK01-10020-000	Cable Ring	2
12	UF-2200EHX-CP-012	DK20-10018-000	Wiring Terminal	12
13	UF-2200EHX-CP-013	DK20-10020-000	Fixing Board	1
14	UF-2200EHX-CP-014	5301-00005-000	Flat Washer, D5	4
15	UF-2200EHX-CP-015	JK01-10029-000	Screw, M3 x 6.5mm	4
16	UF-2200EHX-CP-016	JK02-10021-000	Connection Rail	1
17	UF-2200EHX-CP-017	JK01-JD000-000	Ground Decal	1
18	UF-2200EHX-CP-018	JK01-10014-000	Ground End	1
19	UF-2200EHX-CP-019	JK01-10005-000	Contactora	1
20	UF-2200EHX-CP-020	JK01-10031-000	Screw, M3.5 x 12mm	2
21	UF-2200EHX-CP-021	JK01-10030-000	Screw, M3.5 x 9.5mm	10
22	UF-2200EHX-CP-022	MK01-10008-000	Fuse, 30A	3
23	UF-2200EHX-CP-023	JK01-10010-100	Fuse, 1A	2
24	UF-2200EHX-CP-024	JK01-10011-000	Fixing Board	1
25	UF-2200EHX-CP-025	JK01-10009-000	Fuse Seat	2
26	UF-2200EHX-CP-026	JK01-10009-001	Fuse Seat Board	1
27	UF-2200EHX-CP-027	JK01-10003-000	Connection Rail	1
28	UF-2200EHX-CP-028	DK09-10007-000	Double Fuse Seat	1
29	UF-2200EHX-CP-029	DK09-10004-000	Wiring Terminal	1
30	UF-2200EHX-CP-030	5202-00004-000	Nut	1
31	UF-2200EHX-CP-031	MK01-00102-000	Bridge Rectifier	1
32	UF-2200EHX-CP-032	5110-04016-000	Screw, M4 x 16mm	1

## Exploded View – (Power Unit)

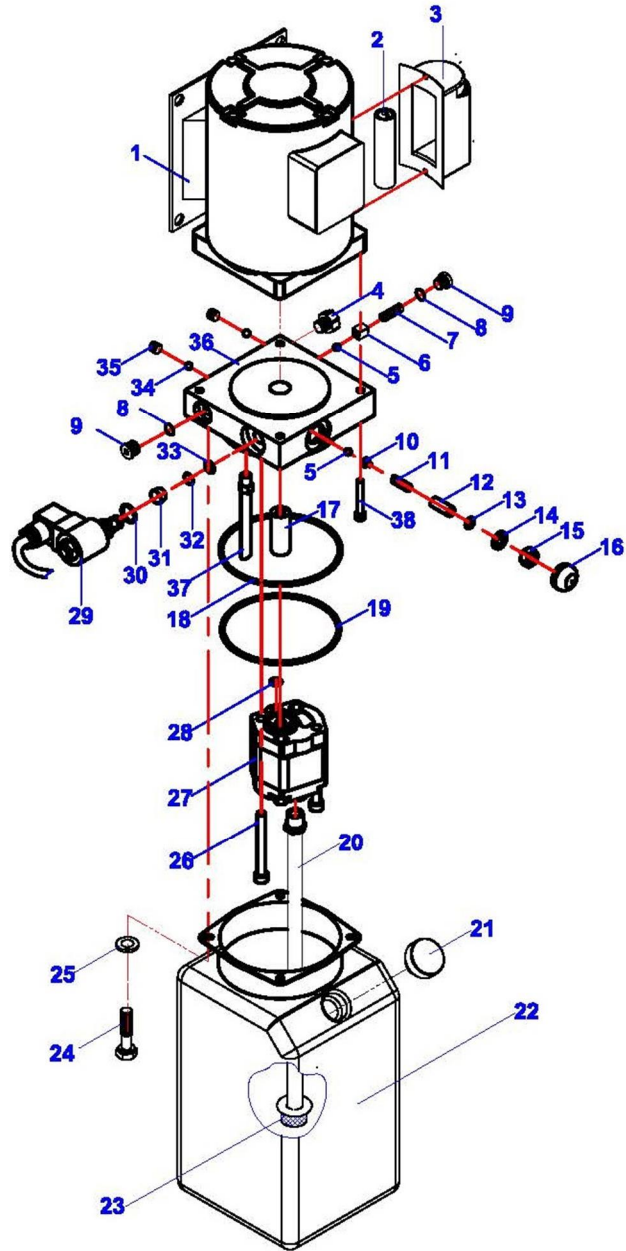

## Parts List – (Power Unit)

ITEM	Tux P/N	M-Ref P/N	DESCRIPTION	QTY
1	UF-2200EHX-PU-001	BZ13-05001-000	Motor 110VAC-1Ph 60Hz	1
2	UF-2200EHX-PU-002	BZ14-05002-B00	Start Capacitor	1
3	UF-2200EHX-PU-003	BZ14-05003-000	Capacitor Cover	1
4	UF-2200EHX-PU-004	BZ01-04010-000	Cap Nut-A	1
5	UF-2200EHX-PU-005	5601-00635-000	Steel Ball	2
6	UF-2200EHX-PU-006	BZ01-04007-000	Ball Seat	1
7	UF-2200EHX-PU-007	BZ01-04009-000	Spring	1
8	UF-2200EHX-PU-008	5901-00118-000	O-Ring	2
9	UF-2200EHX-PU-009	BZ01-04008-000	Cap Nut-B	1



10	UF-2200EHX-PU-010	BZ01-04005-000	Ball Seat	1
11	UF-2200EHX-PU-011	BZ01-04002-000	Spring	1
12	UF-2200EHX-PU-012	BZ01-04003-000	Threaded Pin	1
13	UF-2200EHX-PU-013	5901-00072-000	O-Ring, D7.2 x 2.4mm	1
14	UF-2200EHX-PU-014	BZ01-04016-000	Special Washer	1
15	UF-2200EHX-PU-015	BZ01-04004-000	Lock Nut	1
16	UF-2200EHX-PU-016	BZ01-04-12-000	Protective Cap	1
17	UF-2200EHX-PU-017	BZ14-00003-000	Coupler	1
18	UF-2200EHX-PU-018	5901-01150-000	O-Ring, D115 x 3.55mm	1
19	UF-2200EHX-PU-019	5901-01120-000	O-Ring, D112 x 3.55mm	1
20	UF-2200EHX-PU-020	JP16-01001-000	Suction Tube	1
21	UF-2200EHX-PU-021	BZ13-02101-S00	Fill Cap	1
22	UF-2200EHX-PU-022	BZ13-02100-S00	Plastic Reservoir	2
23	UF-2200EHX-PU-023	BZ01-01002-000	Filter	1
24	UF-2200EHX-PU-024	5117-06012-000	Lock Nut, M6 x 12mm	4
25	UF-2200EHX-PU-025	5302-00006-000	Flat Washer, D4	4
26	UF-2200EHX-PU-026	5105-08075-000	Bolt, M8 x 75mm	2
27	UF-2200EHX-PU-027	BZ14-03000-B00	Gear Pump	1
28	UF-2200EHX-PU-028	5901-00008-000	O-Ring, D8 x 2mm	1
29	UF-2200EHX-PU-029	BZ13-04100-000	Solenoid Release Valve	1
30	UF-2200EHX-PU-030	5901-00160-000	O-Ring, D16 x 2mm	1
31	UF-2200EHX-PU-031	BZ01-04011-000	Filter	1
32	UF-2200EHX-PU-032	5901-00095-000	O-Ring, D9.5 x 1.8mm	1
33	UF-2200EHX-PU-033	5901-00125-000	O-Ring, D12 x 1.5mm	1
34	UF-2200EHX-PU-034	5601-00800-000	Steel Ball, D8	2
35	UF-2200EHX-PU-035	BZ01-00002-000	Threaded Pin, M10 x 8mm	2
36	UF-2200EHX-PU-036	BZ30-04001-000	Valve Block	1
37	UF-2200EHX-PU-037	BZ14-00001-000	Return Tube	1
38	UF-2200EHX-PU-038	5105-06040-000	Screw, M6 x 40mm	4

## 7. Troubleshooting Guide

<b>A.</b>	<b>Problem</b>	<b>Motor does not run.</b>
	Possible cause:	Solution:
	<ol style="list-style-type: none"> <li>1. Blown fuse or circuit breaker.</li> <li>2. Incorrect voltage to motor.</li> <li>3. Bad wiring connections.</li> <li>4. Motor up switch burned out.</li> <li>5. Overhead limit switch burned out.</li> <li>6. Motor windings burned out.</li> </ol>	<ol style="list-style-type: none"> <li>1. Replace fuse or reset circuit breaker.</li> <li>2. Supply correct voltage to motor.</li> <li>3. Repair and insulate all connections.</li> <li>4. Replace switch.</li> <li>5. Replace switch.</li> <li>6. Replace motor.</li> </ol>
<b>B.</b>	<b>Problem</b>	<b>Motor runs but lift will not raise.</b>
	Possible cause:	Solution:
	<ol style="list-style-type: none"> <li>1. Open lowering valve.</li> <li>2. Pump sucking air.</li> <li>3. Suction stub off pump.</li> <li>4. Low oil level.</li> </ol>	<ol style="list-style-type: none"> <li>1. Repair or replace lowering valve.</li> <li>2. Tighten all suction line fittings.</li> <li>3. Replace suction stub.</li> <li>4. Fill tank with SAE-10, AW 32 or equivalent.</li> </ol>
<b>C.</b>	<b>Problem</b>	<b>Lift will raise up only without load.</b>
	Possible cause:	Solution:
	<ol style="list-style-type: none"> <li>1. Motor running on low voltage.</li> <li>2. Debris in lowering valve.</li> <li>3. Improper relief valve adjustment.</li> <li>4. Overloading.</li> </ol>	<ol style="list-style-type: none"> <li>1. Supply correct voltage to motor.</li> <li>2. Clean lowering valve.</li> <li>3. Replace relief valve cartridge.</li> <li>4. Check or balance the vehicle weight on lift.</li> </ol>
<b>D.</b>	<b>Problem</b>	<b>Lift slowly settles down.</b>
	Possible cause:	Solution:
	<ol style="list-style-type: none"> <li>1. Debris in check valve seat.</li> <li>2. Debris in lowering valve seat.</li> <li>3. External oil leaks.</li> </ol>	<ol style="list-style-type: none"> <li>1. Clean check valve.</li> <li>2. Clean lowering valve.</li> <li>3. Repair external leaks.</li> </ol>
<b>E.</b>	<b>Problem</b>	<b>Slow lifting speed or oil blowing out breather cap</b>
	Possible cause:	Solution:
	<ol style="list-style-type: none"> <li>1. Air mixed with oil.</li> <li>2. Air mixed with oil suction.</li> <li>3. Oil over filled.</li> <li>4. Debris in check valve seat.</li> <li>5. Debris in lowering valve seat.</li> </ol>	<ol style="list-style-type: none"> <li>1. Change oil to non-foaming SAE-10, AW 32 or equivalent.</li> <li>2. Tighten all suction line fittings.</li> <li>3. Only fill or add oil to tank when lift is fully lowered.</li> <li>4. Clean check valve.</li> <li>5. Clean lowering valve.</li> </ol>
<b>H.</b>	<b>Problem</b>	<b>Locking latches do not engage.</b>
	Possible cause:	Solution:
	<ol style="list-style-type: none"> <li>1. Latches and/or shafts rusted.</li> <li>2. Release the lock without lifting.</li> <li>3. Latch cable broken or bad connection.</li> </ol>	<ol style="list-style-type: none"> <li>1. Remove covers, oil latch mechanism. (Depress latch release handle several times to allow oil to coat shaft.)</li> <li>2. Raise lift a short distance first.</li> <li>3. Check cable connection or replace.</li> </ol>

## **LIMITED WARRANTY**

### **Structural Warranty:**

The following parts and structural components carry a five year warranty:

Columns	Arms	Uprights	Swivel Pins Legs	Carriages	Overhead Beam
Tracks	Cross Rails	Top Rail Beam			

### **Limited One-Year Warranty:**

Tuxedo Distributors, LLC (iDEAL) offers a limited one-year warranty to the original purchaser of Lifts and Wheel Service equipment in the United States and Canada. Tuxedo will replace, without charge, any part found defective in materials or workmanship under normal use, for a period of one year after purchase. The purchaser is responsible for all shipping charges. This warranty does not apply to equipment that has been improperly installed or altered or that has not been operated or maintained according to specifications.

### **Other Limitations:**

This warranty does not cover:

1. Parts needed for normal maintenance
2. Wear parts, including but not limited to cables, slider blocks, chains, rubber pads and pulleys
3. Replacement of lift and tire changer cylinders after the first 30 days. A seal kit and installation instructions will be sent for repairs thereafter.
4. On-site labor

Upon receipt, the customer must visually inspect the equipment for any potential freight damage before signing clear on the shipping receipt. Freight damage is not considered a warranty issue and therefore must be noted for any potential recovery with the shipping company.

The customer is required to notify Tuxedo of any missing parts within 72 hours. Timely notification must be received to be covered under warranty.

Tuxedo will replace any defective part under warranty at no charge as soon as such parts become available from the manufacturer. No guarantee is given as to the immediate availability of replacement parts.

Tuxedo reserves the right to make improvements and/or design changes to its lifts without any obligation to previously sold, assembled or fabricated equipment.

There is no other express warranty on the Tuxedo lifts and this warranty is exclusive of and in lieu of all other warranties, expressed or implied, including all warranties of merchantability and fitness for a particular purpose. To the fullest extent allowed by law, Tuxedo shall not be liable for loss of use, cost of cover, lost profits, inconvenience, lost time, commercial loss or other incidental or consequential damages.

This Limited Warranty is granted to the original purchaser only and is not transferable or assignable.

Some states do not allow exclusion or limitation of consequential damages or how long an implied warranty lasts, so the above limitations and exclusions may not apply. This warranty gives you specific legal rights and you may have other rights, which may vary from state to state.

8320 E Hwy 67, Alvarado, TX 76009  
Ph. 817-558-9337 / Fax 817-558-9740